

DTIC FILE COPY

1



AD-A211 799

U.S. Army Research Institute  
for the Behavioral and Social Sciences

Research Report 1524

# MANPRINT Evaluation: AN/TRC-170 Digital Troposcatter Radio System

Gregory S. Krohn and Samuel E. Bowser  
Essex Corporation

DTIC  
ELECTE  
AUG 28 1989  
S D CS D

June 1989

Approved for public release; distribution is unlimited.

89 8 14 003

# U.S. ARMY RESEARCH INSTITUTE FOR THE BEHAVIORAL AND SOCIAL SCIENCES

A Field Operating Agency Under the Jurisdiction  
of the Deputy Chief of Staff for Personnel

**EDGAR M. JOHNSON**  
Technical Director

**JON W. BLADES**  
COL, IN  
Commanding

---

Research accomplished under contract  
for the Department of the Army

Essex Corporation

Technical review by

Peter J. Legree  
Edward W. Sullivan

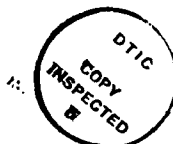

Accession For
NEWS
DTIC
...

A-1

## NOTICES

**DISTRIBUTION:** Primary distribution of this report has been made by ARI. Please address correspondence concerning distribution of reports to: U.S. Army Research Institute for the Behavioral and Social Sciences, ATTN: PERI-POX, 5001 Eisenhower Ave., Alexandria, Virginia 22333-5600.

**FINAL DISPOSITION:** This report may be destroyed when it is no longer needed. Please do not return it to the U.S. Army Research Institute for the Behavioral and Social Sciences.

**NOTE:** The findings in this report are not to be construed as an official Department of the Army position, unless so designated by other authorized documents.

## REPORT DOCUMENTATION PAGE

1a. REPORT SECURITY CLASSIFICATION Unclassified		1b. RESTRICTIVE MARKINGS --	
2a. SECURITY CLASSIFICATION AUTHORITY --		3. DISTRIBUTION/AVAILABILITY OF REPORT Approved for public release; distribution is unlimited.	
2b. DECLASSIFICATION/DOWNGRADING SCHEDULE --			
4. PERFORMING ORGANIZATION REPORT NUMBER(S) --		5. MONITORING ORGANIZATION REPORT NUMBER(S) ARI Research Report 1524	
6a. NAME OF PERFORMING ORGANIZATION Essex Corporation	6b. OFFICE SYMBOL (If applicable) --	7a. NAME OF MONITORING ORGANIZATION U.S. Army Research Institute Field Unit at Fort Hood, Texas	
6c. ADDRESS (City, State, and ZIP Code) 741 Lakefield Road, Suite B Westlake Village, CA 91361		7b. ADDRESS (City, State, and ZIP Code) HQ TEXCOM (PERI-SH) Fort Hood, TX 76544-5065	
8a. NAME OF FUNDING/SPONSORING ORGANIZATION U.S. Army Research Institute for the Behavioral and Social Sciences	8b. OFFICE SYMBOL (If applicable) PERI-3	9. PROCUREMENT INSTRUMENT IDENTIFICATION NUMBER MDA903-86-C-0341	
8c. ADDRESS (City, State, and ZIP Code) 5001 Eisenhower Avenue Alexandria, VA 22333-5600		10. SOURCE OF FUNDING NUMBERS	
		PROGRAM ELEMENT NO. 63739A	PROJECT NO. 793
		TASK NO. 151	WORK UNIT ACCESSION NO. C3
11. TITLE (Include Security Classification) MANPRINT Evaluation: AN/TRC-170 Digital Troposcatter Radio System			
12. PERSONAL AUTHOR(S) Krohn, Gregory S., and Bowser, Samuel E. (Essex Corporation)			
13a. TYPE OF REPORT Final	13b. TIME COVERED FROM 86/10 TO 88/01	14. DATE OF REPORT (Year, Month, Day) 1989, June	15. PAGE COUNT
16. SUPPLEMENTARY NOTATION Contracting Officer's Representative: Charles G. Nystrom			
17. COSATI CODES		18. SUBJECT TERMS (Continue on reverse if necessary and identify by block number)	
FIELD	GROUP	SUB-GROUP	Human factors evaluation, System safety, Manpower, MANPRINT evaluation, Health hazards, Troposcatter communications, Training, (YES)
19. ABSTRACT (Continue on reverse if necessary and identify by block number) This document describes the Manpower and Personnel Integration (MANPRINT) Evaluation of the AN/TRC-170 Digital Troposcatter Radio System. The MANPRINT evaluation was conducted in support of the AN/TRC-170 Follow-On Operational Test and Evaluation (FOT&E) by the U.S. Army Research Institute for the Behavioral and Social Sciences (ARI). The FOT&E was conducted by the U.S. Army Operational Test and Evaluation Agency (OTEA) at Fort Huachuca, AZ, from September 1986 through January 1987. The purpose of the MANPRINT Evaluation was to identify human factors engineering, system safety, health hazards, training, and manpower factors leading to refinements in the AN/TRC-170 system. The MANPRINT evaluation methodology included structured interviews, on-site observations of operations and maintenance, and measures of task performance times. There were 24 MANPRINT findings involving equipment assembly and disassembly, materials handling procedures, and safety during road marches.			
20. DISTRIBUTION/AVAILABILITY OF ABSTRACT <input checked="" type="checkbox"/> UNCLASSIFIED/UNLIMITED <input type="checkbox"/> SAME AS RPT. <input type="checkbox"/> DTIC USERS		21. ABSTRACT SECURITY CLASSIFICATION Unclassified	
22a. NAME OF RESPONSIBLE INDIVIDUAL Charles O. Nystrom		22b. TELEPHONE (Include Area Code) (817) 288-9118	22c. OFFICE SYMBOL PERI-SH

**Research Report 1524**

**MANPRINT Evaluation: AN/TRC-170  
Digital Troposcatter Radio System**

**Gregory S. Krohn and Samuel E. Bowser**  
Essex Corporation

**Field Unit at Fort Hood, Texas**  
**George M. Gividen, Chief**

**Systems Research Laboratory**  
**Robin L. Keesee, Director**

**U.S. Army Research Institute for the Behavioral and Social Sciences**  
**5001 Eisenhower Avenue, Alexandria, Virginia 22333-5600**

**Office, Deputy Chief of Staff for Personnel**  
**Department of the Army**

**June 1989**

---

**Army Project Number**  
**2Q263739A793**

**Soldier-System Consideration in**  
**Force Development Testing**

Approved for public release; distribution is unlimited.

## FOREWORD

---

The primary mission of the Fort Hood Field Unit of the U.S. Army Research Institute for the Behavioral and Social Sciences (ARI) is "to conduct training and human performance research and MANPRINT (Manpower and Personnel Integration) assessments of units and systems in an operational environment in order to develop and expand the MANPRINT data base; support ODCSPER'S responsibilities in test and evaluation as outlined in AR 71-2; and support user tests conducted by OTEA, TEXCOM, and the test boards."

The mission technical objectives are to identify and document unresolved MANPRINT issues and problems experienced by materiel systems undergoing user testing during the materiel acquisition process; to formulate and recommend courses of action in the MANPRINT domains of manpower, personnel, and training that will cost-effectively optimize performance of the system under test; and to report other issues and problems identified in user testing to the appropriate agencies for the MANPRINT domains of human factors engineering, systems safety, and health hazards.

This report presents the results of the ARI MANPRINT evaluation of the AN/TRC-170 Digital Troposcatter Radio System. The AN/TRC-170 system consists of radio terminals that transmit microwave signals that are scattered and reflected off the upper atmosphere and received by other terminals. The radio terminals provide a tactical secure multichannel transmission and reception of analog and digital signal traffic. Messages originate at corps and echelons-above-corps levels and are sent through the radio terminals for microwave transmission and reception.

This research is subsumed under the "Soldier-System Considerations in Force Development Testing" task of the "Human Factors in Training and Operational Effectiveness" project. It was conducted in accordance with the provisions of a Letter of Agreement between the U.S. Army Research Institute (ARI) and the U.S. Army Operational Test and Evaluation Agency (OTEA) dated 15 June 1983.

The contents of this MANPRINT report were incorporated into the OTEA AN/TRC-170 Final Test Report and the OTEA Independent Evaluation Report. The research findings and recommendations were briefed by ARI to the OTEA commanding general, the AN/TRC-170 program manager, and representatives from the AN/TRC-170 TRADOC system manager's office during January 1987. Findings provided the basis for recommendations for improving system effectiveness.



EDGAR M. JOHNSON  
Technical Director

# MANPRINT EVALUATION: AN/TRC-170 DIGITAL TROPOSCATTER RADIO SYSTEM

## EXECUTIVE SUMMARY

---

### Requirement:

The AN/TRC-170 was tested in a Follow-On Operational Test and Evaluation (FOT&E) by the U.S. Army Operational Test and Evaluation Agency (OTEA). The FOT&E was conducted at Fort Huachuca, Arizona, from September 1986 through January 1987. This report describes the Manpower and Personnel Integration (MANPRINT) evaluation support provided to OTEA during the FOT&E by the U.S. Army Research Institute for the Behavioral and Social Sciences (ARI). The purpose of the MANPRINT effort was to identify manpower, personnel, training, human factors engineering, systems safety, and health hazard problems in areas where modification would lead to more effective system performance and maintenance.

### Procedure:

Crews and maintainers were observed while performing AN/TRC-170 operational scenarios. Crewman were administered structured interviews after operational scenarios were completed. Timed crew task performance measures were collected and compared to system emplacement criteria. At an end-of-test scoring conference attended by agency representatives participating in the test, the findings were scored according to their impact on system performance and their priority for corrections.

### Findings:

There were 24 findings of the MANPRINT evaluation. Since the AN/TRC-170 operates as a relay node, many of the findings concerned site emplacement and disemplacement. Most findings involved materials handling difficulties. Four-man crews performed tasks more rapidly than three-man crews; however, the system emplacement criteria were still not met.

### Utilization of Findings:

The findings in this report were integrated into the OTEA Final Test Report and the OTEA Independent Evaluation Report. The correction of identified MANPRINT problems will significantly improve the operational effectiveness of the AN/TRC-170 and increase both crew and maintainer safety.

MANPRINT EVALUATION: AN/TRC-170 DIGITAL TROPOSCATTER RADIO SYSTEM

CONTENTS

	Page
INTRODUCTION . . . . .	1
General . . . . .	1
Description . . . . .	1
METHOD . . . . .	11
Crew Members . . . . .	11
Evaluation Materials . . . . .	11
Evaluation Procedures . . . . .	11
RESULTS . . . . .	14
Detailed Descriptions of Findings . . . . .	14
Task Performance Measures . . . . .	57
DISCUSSION . . . . .	68
REFERENCES . . . . .	69

LIST OF TABLES

Table 1. AN/TRC-170 general operating characteristics . . . . .	2
2. Crewmen and maintainer basic demographics . . . . .	12
3. Performance impact rating scale and correction priority scale . . . . .	15
4. AN/TRC-170 MANPRINT findings summary . . . . .	16
5. Task performance time for V2 set up by number of persons performing the task . . . . .	58
6. Task performance time for V2 tear down by number of persons performing the task . . . . .	60
7. Task performance time for V3 set up by number of persons performing the task . . . . .	61

CONTENTS (Continued)

Page

LIST OF TABLES (Continued)

Table 8.	Task performance time for V3 tear down by number of persons performing the task . . . . .	62
9.	Proportion of criterial emplacements and mean employment times with two measures: Elapsed time and time in criterial tasks . . . . .	67

LIST OF FIGURES

Figure 1.	The operational concept of the AN/TRC-170 V2 system, showing transmissions reflected off the upper atmosphere . . . . .	3
2.	The V2 transport configuration . . . . .	4
3.	The V3 transport configuration . . . . .	5
4.	The emplaced V2 and V3 antennas and shelters . . . . .	7
5.	The mobilizer-mounted V2 S-665 shelter equipment layout along the roadside wall . . . . .	8
6.	The truck-mounted V3 S-666 shelter equipment layout along the roadside wall . . . . .	9
7.	The truck-mounted V3 S-666 shelter equipment layout along the curbside wall . . . . .	10
8.	The M-720 mobilizer carrying the S-665 shelter . . . . .	21
9.	The main power panel in the V3 shelter . . . . .	23
10.	The low-profile pallet that was mounted on a 2.5-ton truck and covered for transport . . . . .	27
11.	The waveguide latches that were difficult to close and the O-ring that fell out . . . . .	32
12.	The waveguide protective container and trailer stowage location . . . . .	33
13.	The waveguides and other cables laid out on the ground prior to installation . . . . .	34



CONTENTS (Continued)

---

Page

LIST OF FIGURES (Continued)

Figure 14.	The lightning protection assembly (LPA) that was erected across the top of the antenna structures . . . . .	36
15.	A cut-away view of the Pionjar drive motor and of the duckbill anchor . . . . .	38
16.	An example of the type of pin that was difficult to insert and remove . . . . .	43
17.	The 9.5-ft. antenna, rear truss clamp, and bearing ball . . . . .	46
18.	An example of the type of manipulation task that could be performed more rapidly by crewmen using a stepladder or platform . . . . .	49
19.	The 9.5-ft. antenna and hand crank that was difficult to use to reach the elevation angle adjustment device . . . . .	50
20.	The interior of the low-profile pallet showing the location of the accessory alignment kit . . . . .	54
21.	The low-profile pallet which was mounted on a 2.5-ton truck . . . . .	56

# MANPRINT EVALUATION: AN/TRC-170 DIGITAL TROPOSCATTER RADIO SYSTEM

## Introduction

### General

This report describes the MANPRINT Evaluation of the Army AN/TRC-170 Digital Troposcatter Radio System. The MANPRINT Evaluation was performed in conjunction with the AN/TRC-170 Follow-On Operational Test and Evaluation (FOT&E) conducted at Fort Huachuca, AZ, from September 1986 through January 1987. Further, it was conducted in support of the U.S. Army Operational Test and Evaluation Agency (OTEA) by the U.S. Army Research Institute for the Behavioral and Social Sciences (ARI) Fort Hood, TX, Field Unit.

The purpose of the MANPRINT Evaluation was to identify manpower, training, human factors engineering, system safety, and health hazard problems where modification would lead to more effective performance or maintenance of the AN/TRC-170 system. Since the personnel requirements for the system were defined by TRADOC well in advance of the FOT&E, they are not reexamined here. The evaluation produced information about several areas where improvement was feasible. It was judged that changes could be made without unreasonable expense while remaining within the system's configuration constraints.

### Description

Table 1 lists the general operating characteristics of the AN/TRC-170 system. The AN/TRC is a radio terminal, transmitter, and receiver that is manufactured in three versions: V1, V2, and V3. The FOT&E tested only the V2 and V3 systems. Figure 1 shows the operational concept of the AN/TRC-170 radio terminals which transmit microwave signals scattered and reflected off the upper atmosphere. The radio terminals provide a tactical secure multi-channel transmission and reception of analog and digital signal traffic. Messages originate at the Corps and Echelons above Corps levels, and are sent through the radio terminals for microwave scattered transmission and reception.

Figures 2 and 3 show the differing V2 and V3 transport configurations. The V2 system's transport configuration centered around the low-profile pallet carried on a 2.5-ton truck and the S655 shelter carried on the M-720 mobilizer. The low-profile pallet carried the parts and accessory equipment for the 9.5-ft antenna that operated at ranges of 150 to 200 miles. The V3 transport configuration centered around the trailer mounted quick reaction antenna (QRA). The V3 antenna was smaller and was to be erected more rapidly than the V2 antenna. However, the V3 antenna only operated at ranges to 100 miles. The V3 S666 shelter was mounted on a 2.5-ton truck.

Table 1

AN/TRC-170 General Operating Characteristics

Prime Power 120/208 Vac; 3 phase 5 wire, 50, 60 or 400 Hz  
 Radio Frequency 4.4 to 5.0 GHz  
 Frequency Control Frequency synthesizer, rubidium reference, 100 Khz increments  
 Bandwidth 3.5 or 7 MHz  
 TROPO Mode 2 kw max  
 LOS Mode 0.4 w minimum  
 IF Frequency 70 MHz  
 Multiplex Digital Group Multiplex equipment operating at 16 or 32 Kbs  
 Order wire voice and data

	V2	V3
Shelter	S-280	S-250
Height	83 in (211 cm)	70 in (177.8 cm)
Width	87 in (221 cm)	79 in (200.7 cm)
Length	147 in (373 cm)	85 in (215.9 cm)
Pallet Dimensions (V2)		
Trailer Dimensions (V3)		
Height	52 in (132 cm)	80 in (203.2 cm)
Width	87 in (221 cm)	89 in (226 cm)
Length	147 in (373 cm)	147 in (373 cm)
Weight (Combined)	8472 lbs (3843 Kg)	5850 lbs (2654 Kg)
Setup Time	5 hrs/4-person crew	1 hr/2-person crew
Antennas	Two 9.5 ft (2.9 m) diameter reflector dishes at 10-ft or 15-ft height	Two 6.0 ft (180 cm) diameter reflector at 12-ft height (QRA)
Diversity	Quad or Dual (Space and/or frequency)	Dual (Space only)

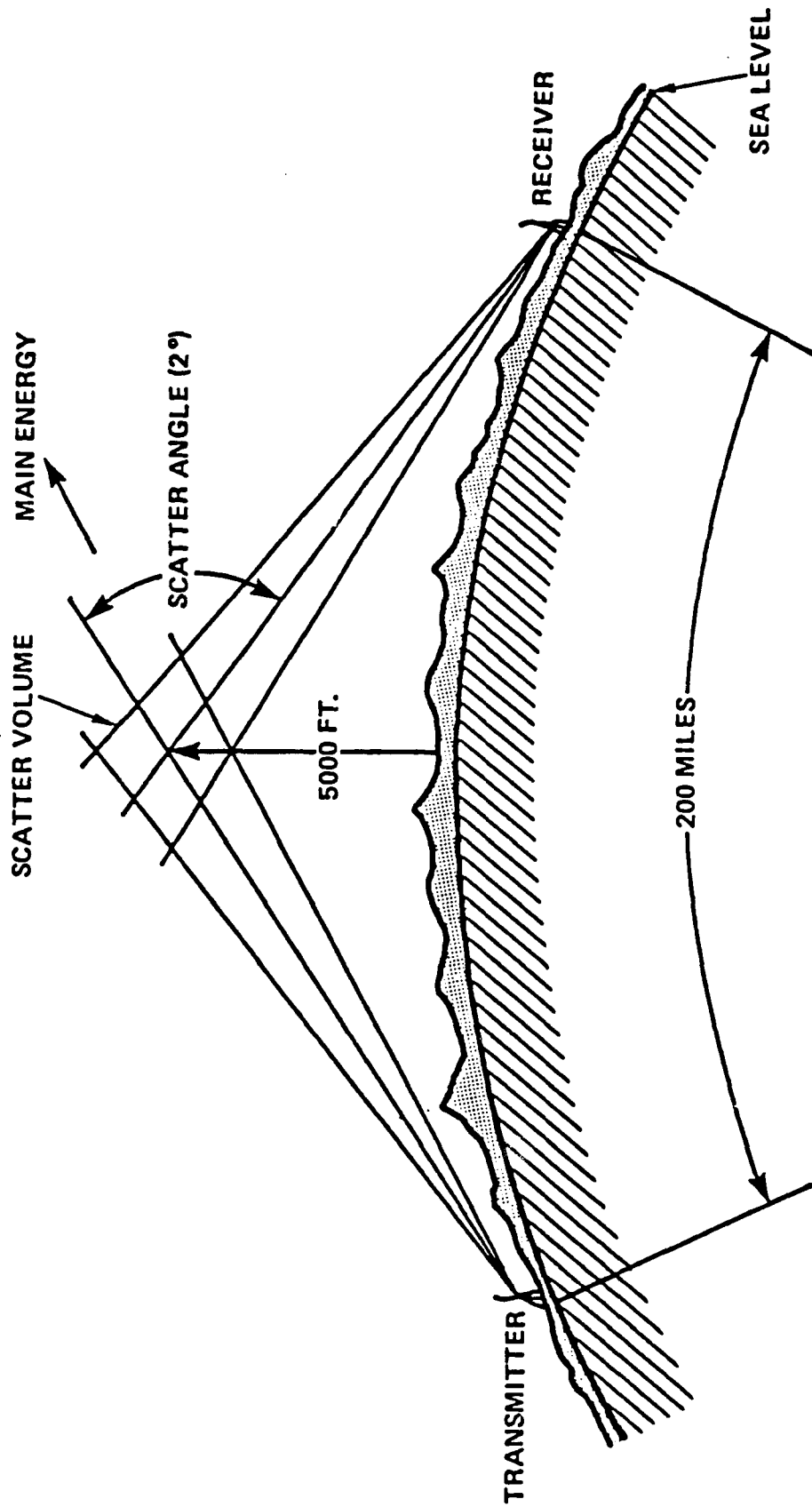

Figure 1. The operational concept of the AN/TRC-170 V2 system, showing transmissions reflected off the upper atmosphere.

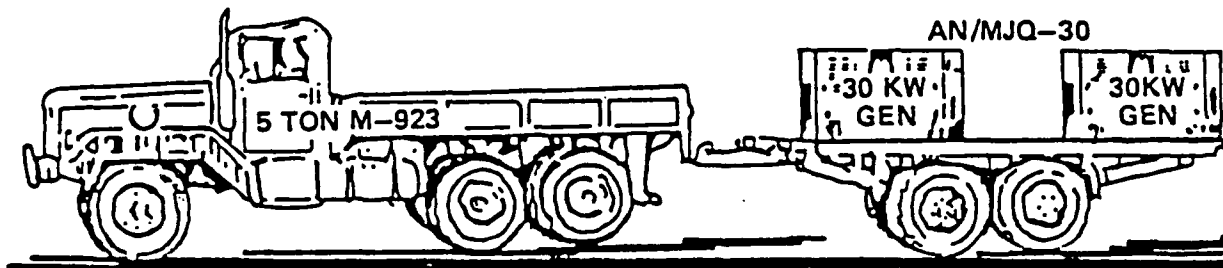
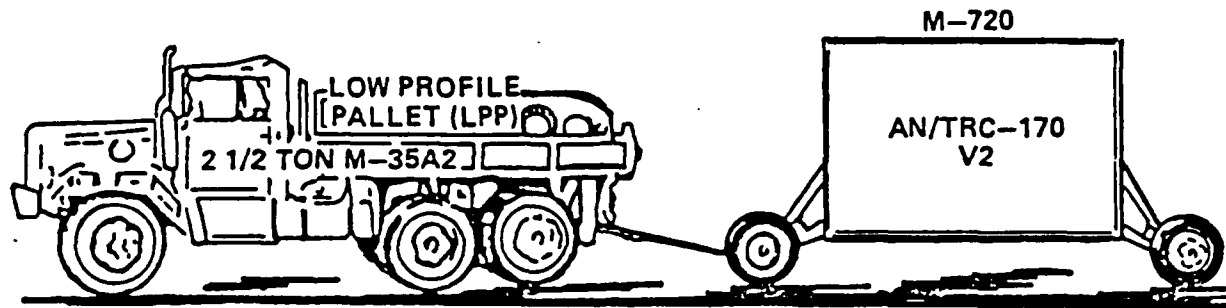

Figure 2. The V2 transport configuration.

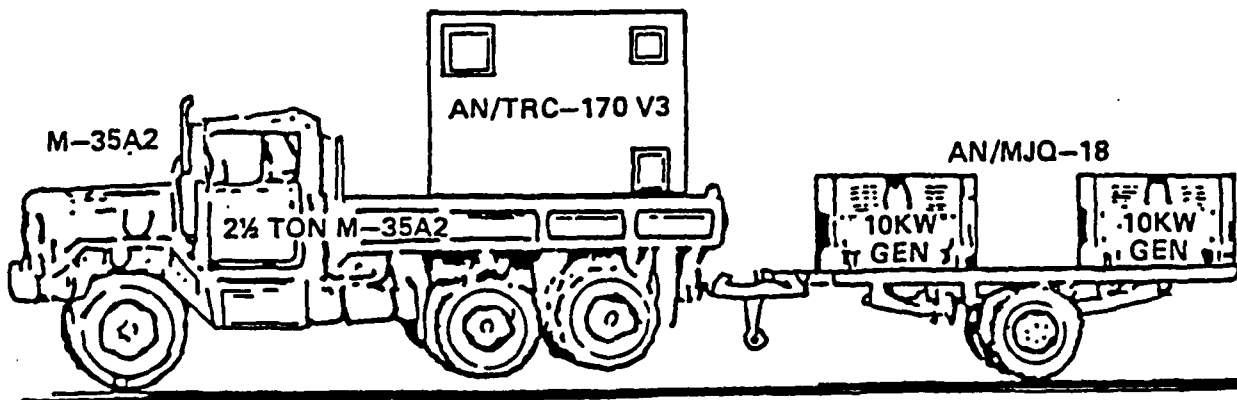
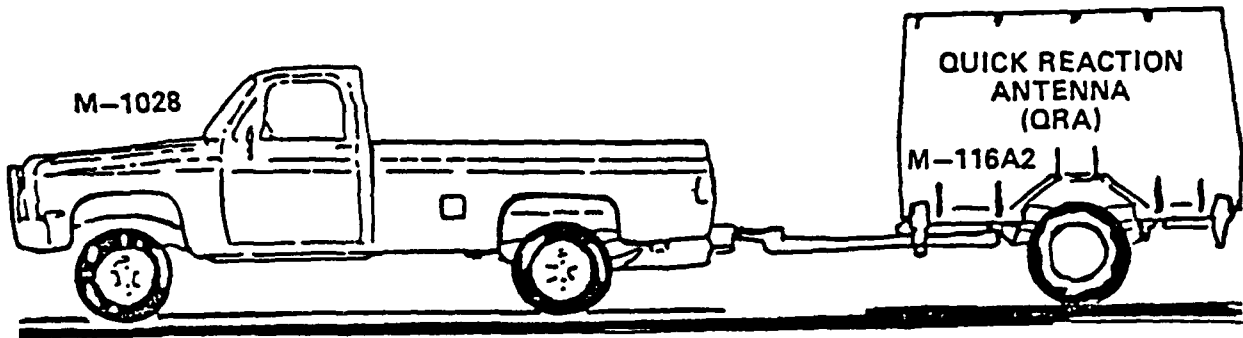
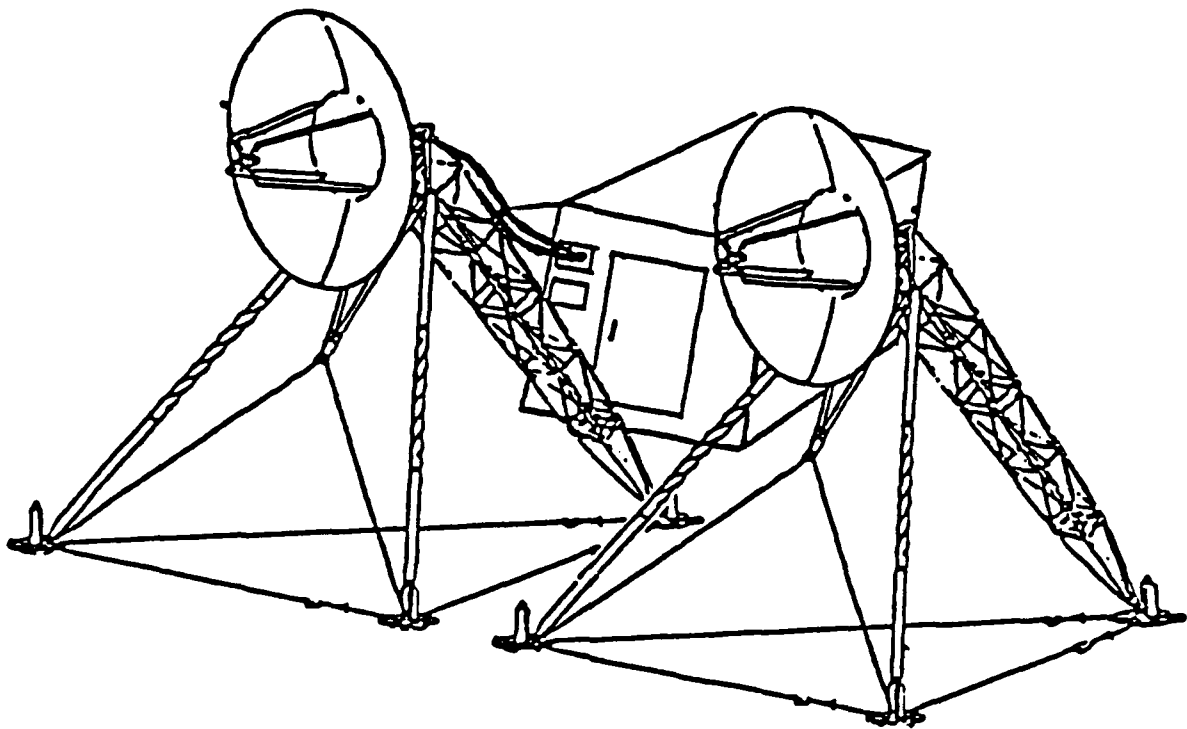

Figure 3. The V3 transport configuration.

Figure 4 shows the V2 and V3 antennas and shelters as they were deployed in the field. Figure 5 shows the layout of the V2 mobilizer-mounted S-665 shelter. All the radio components were mounted on the roadside (left) wall while mobilizer parts, miscellaneous equipment and crewmen basic issue items (BII) were stowed on the curbside (right) wall. Figure 6 and 7 show the layout of the V3 truck mounted shelter for the roadside (left) and curbside (right) wall, respectively. During the FOT&E, six V2 models and four V3 models were tested.

A special tool supplied to the V2 and V3 crews was a handheld Pionjar drill similar to a jack hammer. The Pionjar was used to drill holes in soil for inserting duckbill anchors and to drive in the anchors. The anchor holes could be drilled to a depth of 5 ft and were used to secure the 9.5-ft V2 antenna and the lightening protection assembly. The Pionjar was driven by a 2-cycle gasoline engine and weighed approximately 16 lbs.



a. The V2 antenna and shelter.

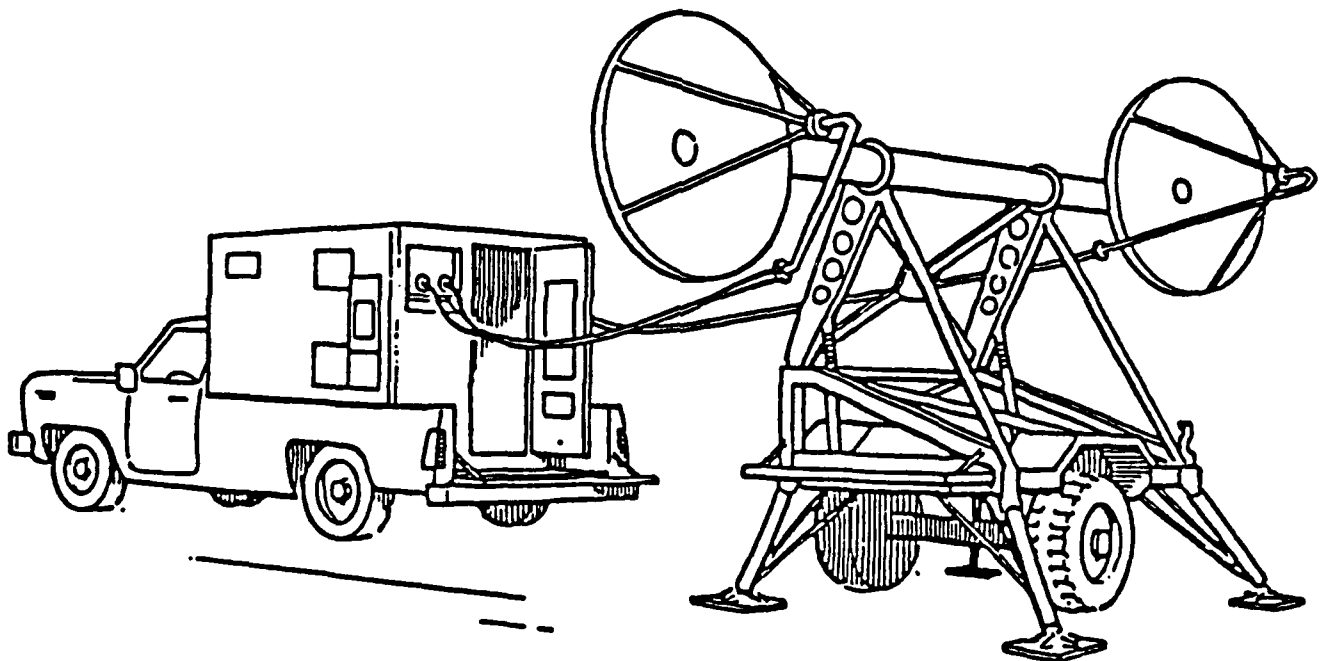

b. The V3 antenna and shelter.

Figure 4. The emplaced V2 (a) and V3 (b) antennas and shelters.



1	POWER DISTRIBUTION UNIT 1A1	2	3	4	5	6	7
	SURGE PROTECTION FAULT ASSY 1A2	RF AMPLIFIER 2A2	RF AMPLIFIER 3A2	RECEIVER AMPLIFIER-CONVERTER 4A2	TRUNK ENCRYPTION DEVICES 5A1A1 - A2	BASEBAND PATCH PANEL 6A1	DLEED PATCH PANEL 7A1
		TRANSMITTER AMPLIFIER-CONVERTER 3A1		RECEIVER AMPLIFIER-CONVERTERS 4 A 4 A 1 1 A 1 A 2	DEDICATED LOOP ENCRYPTION DEVICES 5A2A1 - A2	LOOP GROUP MULTIPLEXER 6A2	ANALOG VOICE ORDERWIRE 7A8
				TRANSMITTER-CONVERTER 4A2	TROPO MODEM MODULATOR 5A3	GROUP MODEM 6A3	ALARM MONITOR 7A2
					FREQUENCY SYNTHESIZER 5A4	TRUNK GROUP MULTIPLEXER 6A4	VOICE ORDERWIRE CONTROL UNIT 7A3
					FREQUENCY SYNTHESIZER 5A5	LOW SPEED CABLE DRIVER MODEM 6A5	
				RECEIVER AMPLIFIER-CONVERTERS 4 4 A A 3 3 A A 2 3	TROPO MODEM DEMODULATOR 5A6	AC TO AC CONVERTER 6A7	IF TEST PANEL 7A5
				NOISE SOURCE 4A4	LOW VOLTAGE POWER SUPPLY 5A7	LOW VOLTAGE POWER SUPPLY 6A6	HEATER ASSY 7A6
							AC 10 AC CONVERTER 7A7

Figure 5. The mobilizer-mounted V2 S-665 shelter equipment layout along the roadside wall. (No components were mounted on the curbside wall.)

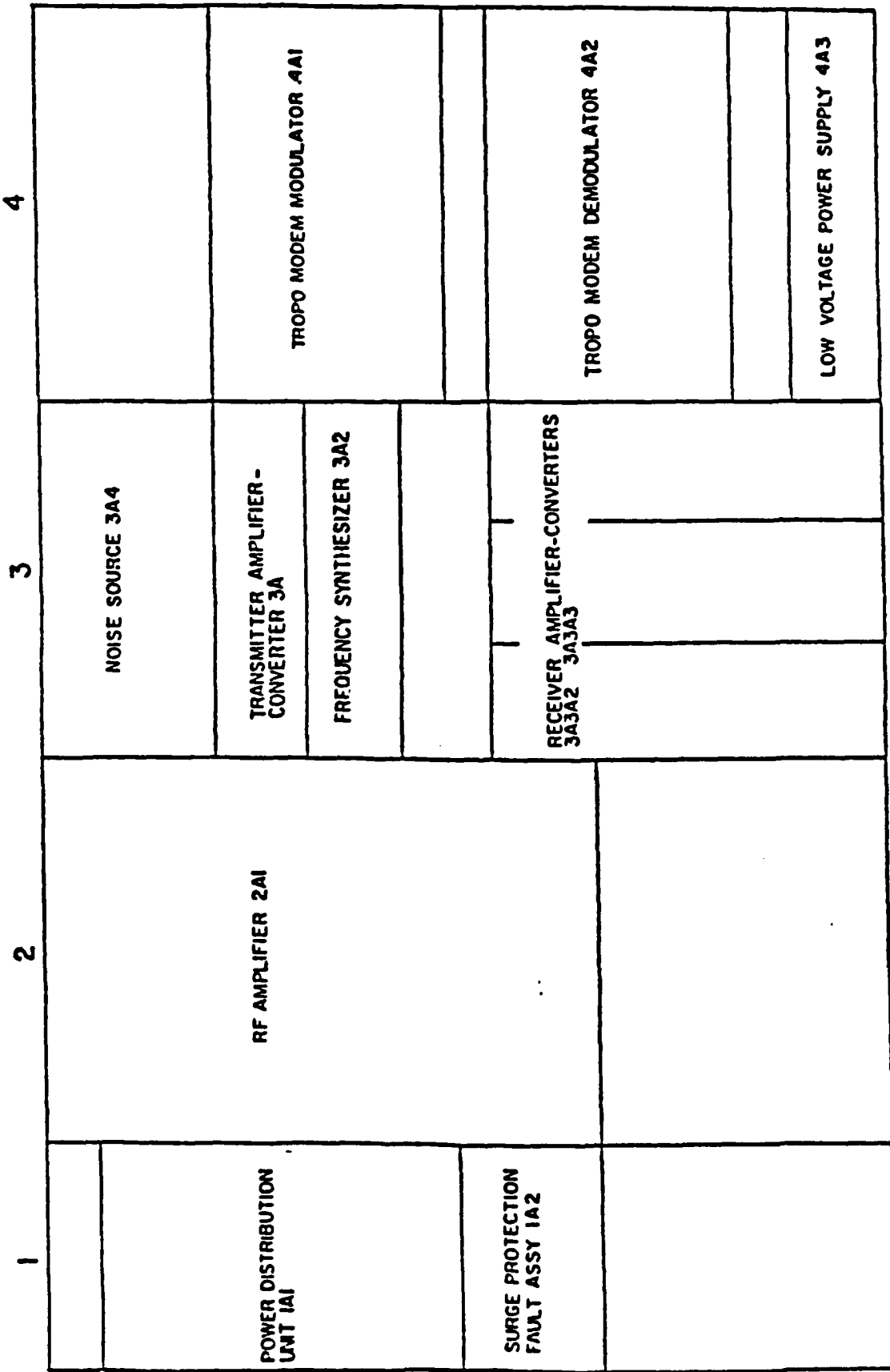

Figure 6. The truck-mounted V3 S-666 shelter equipment layout along the roadside wall.



## Method

### Crew Members

Thirty-eight (38) crewmen and maintainers participated in the test. Table 2 lists the basic biographical data for the soldiers. The V2 and V3 crews consisted of three crewmen. Each maintainer maintained three or more V2 or V3 units.

### Evaluation Materials

Structured interviews were developed for data collection during the AN/TRC-170 FOT&E. The data collection forms and raw data are contained in a separate report (Bowser, 1987). The structured interviews were designed to investigate the test data requirements and related MANPRINT concerns. Items in the structured interviews were listed as questions with yes, no, and comment response formats. The yes and no responses were tallied and comments were listed. The comments made by the test participants were open-ended in format. The interview forms included:

1. Operator Interview
2. Maintainer Interview
3. Test Directorate Interview
4. Unit Interview
5. Data Collector Interview
6. Operator Training Interview.

Noise levels within the V2 and V3 shelters were measured using an octave band analyzer while the equipment was operating in the high-power transmission mode. The octave band analyzer measured the 500 to 200 hertz range. The octave band analyzer was calibrated by the Fort Hood range instrumentation facility prior to the FOT&E.

### Evaluation Procedures

Initial coordination meetings were conducted with the U.S. Army OTEA MANPRINT project officer and test data manager in July 1986. The initial scope of the evaluation was discussed and it was recognized that a full training evaluation was required. The full training evaluation was reported in a separate document titled Training Assessment: The AN/TRC-170 Digital Troposcatter Radio System (Heuckeroth, 1988). The data collection materials were reviewed and approved by the OTEA and ARI designates in October 1986. In the same month, test site visit dates were set, and test controller and data collectors were briefed on how they could contribute to collecting MANPRINT data.

The structured interviews were conducted individually on the field site. Crewmen were encouraged to demonstrate equipment problems when it was appropriate.

Table 2

Crewmen and Maintainer Basic Demographics

---

Operators

N = 35

MOS: 26QD6

Grade: E5 = 4      E4 = 6      E3 = 25

Mean Age: 21.0

Mean Time in Military: 2.3 years

Mean Time in MOS: 1.4 years

Mean Civilian Education: 12.2 years

Mean Military Education: 7.0 months

Military Schools Attended (average): 2

Respondents Per System: V2 = 19      V3 = 11      Section Chiefs = 5

Maintainers

N = 3

MOS: 29M

Grade: E4 = 3

Mean Age: 27.6

Mean Time in Military: 3.8 years

Mean Time in MOS: 2.6 years

Mean Civilian Education: 12.6 years

Mean Military Education: 13.6 months

Military Schools Attended (average): 3

Respondents Per System: 3

---

Observations of AN/TRC-170 crews performing operations and tasks were conducted throughout the test. Ten AN/TRC-170 terminals were deployed in pairs occupying five tactical sites during testing. The terminals were re-deployed every 96 hours, moving 104 times during day and night conditions. During Phase III of the test, networks were established simulating a corps nodal network, a skip node network, and a corps network using the traffic loading device. No threat, electronic warfare, or nuclear, biological, and chemical (NBC) tactics were simulated during the test. Test Operations Procedure 7-2-610 (November, 1983) was used to guide the on-site observations. Observations were used to identify unanticipated problems of AN/TRC-170 operations and to extend the MANPRINT specialist's understanding of findings from the analysis of structured interviews.

Instrumented measures of noise levels within the shelter were measured with the doors opened and closed. The octave band sensor was held at 36 inches above the floor at approximately the ear height of a seated operator.

Task performance timed measures were collected for crewmen performing site emplacement and disemplacement tasks. The purpose of the timed measures was to examine the task time lines in comparison to the system emplacement and disemplacement time criteria. Lengthy task performance times may suggest tasks requiring procedural modification, job aids, and tools. The AN/TRC-170 is a microwave terminal, and as such, the majority of crew tasks involve set-up and tear-down tasks. Once the terminal is emplaced, crewmen monitor terminal functions and no complex operational tasks occur. Thus, the majority of the crew responsibility is focused on the rapid and proper assembly and disassembly of the equipment. Forty-two timed measures were collected by test data collectors. Test data collectors were briefed on the data element definitions (operational definitions) for each of the measures and then observed in the field to ensure that they understood the measure start and stop cues. Measures of task errors were not collected as prescribed operating procedures were being revised by the manufacturer. Thus, procedural task errors could not be distinguished from crew-implemented efficiencies.

The MANPRINT findings were compiled by the OTEA Human Factors Specialist into a Scoring Conference Booklet. For each problem, the following information was provided: 1) problem number, 2) problem title, 3) MANPRINT category, 4) tentative problem/correction priority, 5) information sources, 6) description of problem, 7) implications, 8) statistics, 9) potential solutions. Manufacturer's (Raytheon) representatives attended to provide a source of technical information. Problem and correction criteria ratings were determined by a majority of the voting participants, who were: 1) OTEA Human Factors Specialist, 2) OTEA Operational Test Director, 3) TRADOC (TMS) representative, 4) CECOM Project Manager representative, and 5) TECOM representative. The findings were reviewed individually and then scored by consensus at the end of the test. The rating scales are listed in the results section of the report.

## Results

Twenty-four MANPRINT findings were found regarding the equipment of the AN/TRC-170. Table 3 lists the performance impact and correction priority rating scales used to score the MANPRINT findings. Table 4 lists a summary description of the 24 MANPRINT findings. Following the summary table are detailed descriptions of the findings. Finally, a review of the timed task performance measures is presented.

### Detailed Descriptions of Findings

Detailed descriptions of each of the 24 MANPRINT findings are presented on pages 18 through 56.

Table 3

Performance Impact Rating Scale and Correction Priority Scale

---

I. Performance Impact

- A. The design deficiency has a significant impact on human performance, leading to a high probability of mission failure, damage to the vehicles, or injury to personnel. Problem solution considered essential for production model.
- B. The design deficiency has a significant impact on human performance, leading to a high probability of degraded mission capacity. Problem solution should be included in the production model.
- C. The correction of the design deficiency will significantly enhance the operability and/or maintainability of the system.
- D. The design deficiency can be corrected by a hardware change or can be compensated for through training.
- E. The design deficiency has minimal impact on mission. Correction will enhance human performance.

II. Correction Priorities

- 1. Corrective action must be taken before a retest.
  - 2. Corrective action must be incorporated before fielding.
  - 3. Corrective action must be incorporated during fielding.
  - 4. Corrective action would substantially improve performance and should be taken.
  - 5. Corrective action would have minor impact on operation and should be taken if no significant cost is involved.
-



Table 4

## AN/TRC-170 MANPRINT Findings Summary

Finding	Description	Implication	Performance Impact	Correction Priority
1. High frequency radio communications. (V2 and V3)	No high frequency radios have been provided for establishing links nor for communicating with tactical, logistic, and maintenance units.	Mission delays.	1. <u>A</u>	<u>1</u>
2. Mobilizer mobility and load capacity. (V2)	The mobilizer (M720) lacks the ground clearance required for cross-country travel and the load capacity for its cargo. The mobilizer (M720) cannot be moved in reverse due to the height of the hitch and the angle of the mobilizer tongue.	Equipment damage. Mission delays. Delayed emplacement.	2. <u>A</u>	<u>1</u>
3. Generator changeover and power load adjustment. (V3)	The two 10-kw generators cannot provide continuous power during switchover and cannot automatically adjust for load variations.	Equipment damage. Loss link transmission.	4. <u>A</u>	<u>1</u>
4. Noise levels in the shelters. (V2 and V3)	Noise levels in the shelters were measured as high as 89 dB at 125 Hz.	Injury to the crewmen.	5. <u>A</u>	<u>1</u>
5. Steps and handrails on trucks. (V2 and V3)	The truck tailgates did not have steps and handrails for ingress or egress to the shelters.	Injury to the crewmen.	6. <u>A</u>	<u>1</u>
6. Loading and unloading low-profile pallet. (V2)	Lifting the low-profile pallet (9.5-ft antenna) requires more than 3 men.	Injury to the crewmen. Additional manpower required.	7. <u>A</u>	<u>2</u>
7. Hearing protection for Pionjar operators. (Pionjar)	The foam ear plugs used for noise protection, during operation of the Pionjar, were not sufficient for prolonged exposure to noise at 110 dBA.	Crew injury.	8. <u>A</u>	<u>2</u>
8. Training for Pionjar operation. (Pionjar)	Pionjar operation, maintenance, and training are not part of the current 26QDQMS training.	Crew injury.	9. <u>A</u>	<u>2</u>
9. The allocated number of maintainers. (V2 and V3)	Only one maintainer is allocated for each set of two V2 and V3 units.	Repair delay. Lost link transmission.	10. <u>B</u>	<u>1</u>
10. Waveguide damage. (V2 and V3)	Damage to the waveguides resulted from bent pins, loose O-rings, forcibly closed latches, and handling during antenna emplacement.	Equipment damage.	11. <u>B</u>	<u>1</u>
11. Assembly and disassembly of the Lightening Protection Assembly. (V2 and V3)	Three-man crews are insufficient for holding the base plate, the mast, and the two guywires during emplacement.	Crew injury. Equipment damage.	12. <u>B</u>	<u>1</u>
12. Non-militarized Pionjar. (Pionjar)	The Pionjar packaging does not meet military specifications in several areas, including safety warnings, operation manuals, or logistics requirements.	Crew injury. Equipment damage. Operational delays.	13. <u>B</u>	<u>1</u>

Table 4 (Cont'd.)

## AN/TRC-170 MANPRINT Findings Summary

Finding	Description	Implication	Performance Impact	Correction Priority
13. Size of the antenna anchors. (V3)	The large-sized antenna anchor tops are punctured by the Pionjar drive rod when used in hard ground. The anchor is larger (approximately 2 mm) than the drill bit.	Equipment damage. Delayed emplacement.	14. <u>B</u>	<u>1</u>
14. Training topics for collective training. (V2 and V3)	Collective training lacked: 1. Demonstrations of site emplacement. 2. Instruction on radiation hazard zones. 3. Practice of assembly and disassembly tasks. 4. Site camouflage and concealment. 5. Network and link planning. 6. Trouble-shooting procedures. 7. Use of pocket transit. 8. Interfacing the COMSEC device with other components.	Crew injury. Delayed emplacement.	15. <u>B</u>	<u>1</u>
15. No commander for second vehicle in unit. (V2 and V3)	The systems have two vehicles. Three-man crews allow only a driver for the second vehicle.	Violates Army requirement for two crewmen per vehicle.	16. <u>B</u>	<u>2</u>
16. Tactical manning for radio operation and perimeter security. (V2 and V3)	There is insufficient manpower for manning of the V2 and V3 systems for 24-hr operations.	Crew fatigue and degraded crew performance.	17. <u>B</u>	<u>2</u>
17. Attachment pins for the antennas. (V2 and V3)	The attachment pins used to fasten antenna part together and to the low-profile pallet are difficult to remove or insert.	Equipment damage.	18. <u>C</u>	<u>1</u>
18. Binding of the antenna rear truss clamp. (V3)	The antenna rear truss clamp binds and cannot be closed without lifting the loaded base-plate.	Crew injury. Equipment damage.	19. <u>C</u>	<u>1</u>
19. Shelter floor slip-and-fall hazard. (V2 and V3)	The shelter floors do not have non-slip nor anti-static protection.	Injury to crewmen.	20. <u>C</u>	<u>1</u>
20. No ladders for antenna assembly or disassembly. (V2)	Several tasks involved in assembling and disassembling the antenna are beyond the reach of crewmen.	Crew injury. Delayed emplacement.	21. <u>C</u>	<u>2</u>
21. Maintenance access to components. (V3)	No hand and arm space was provided that allowed maintainers to reach fasteners behind components.	Mission delay.	22. <u>C</u>	<u>2</u>
22. Seating in shelters. (V2 and V3)	No seating is provided in the shelters for operators on duty.	Injury to crewmen.	23. <u>C</u>	<u>3</u>
23. Accessory kit location on low-profile pallet. (V2 and V3)	The pocket transit compass stowage location in the middle of the low-profile pallet is difficult to reach.	Delayed emplacement.	24. <u>E</u>	<u>4</u>
24. Walk space for loading and unloading the low-profile pallet. (V2)	Crewmen must walk on the 3-in wide outside edge of the low-profile pallet in order to remove the canvas and ropes.	Crew injury.	25. <u>E</u>	<u>4</u>

Problem Title: High Frequency Radio Communications

System: V2 and V3

MANPRINT Category: Human Factors

Information Sources: On-site observations; operator, data collectors, and Test Directorate opinions; performance and RAM data.

Description of the Problem: The V2 and V3 systems do not include a high frequency (HF) radio. The HF radio is critical to link logistics, engineering and maintenance personnel of the deployed units. The HF radio communications facilitate positioning of the unit and establishing a radio link before microwave transmissions can be made.

Implications: Establishing microwave tropospheric links may be either delayed or prevented without independent HF communications. Management of the maintenance activities at the levels required for testing may not be possible.

Data: During the test, 90% of the Tropo links were established using HF or FM radio assistance. The maintenance system was fully dependent upon HF or FM radio communications.

Potential Solutions: A HF radio should be selected for the AN/TRC-170 and supplied with all systems.

Problem Title: M-720 Mobilizer Mobility and Load Capacity

System: V2

MANPRINT Category: Safety

Information Sources: MIL-STD-1472C, paragraph 5.13.1; on-site observations; AR 750-10, Modification of Materials.

Description of the Problem: Figure 8 shows the M-720 Mobilizer which carries the V2 shelter. The M-720 Mobilizer carrying the V2 electronic and some of the antenna equipment had several limitations on its mobility including:

- a. The loaded mobilizer weighed 8,620 lbs when loaded with tactical cargo. The load was 1,150 lbs over the gross weight of the authorized load of 7,470 lbs. The distribution of the weight was unbalanced when the mobilizer was loaded according to the load plan. The left side wheels carried weights of 2,290 lbs and 2,430 lbs for the front and rear wheels. The loads over the left side wheels were 490 lbs and 630 lbs over the 1,800-lb load limit for each wheel. The right side wheels were weighted below the 1,800-lb. load limit.
- b. The ground clearance of the mobilizer was 12 inches below the center of the trailer. The mobilizer struck terrain during cross-country travel and could not cross rough terrain that could have been crossed by the towing vehicle.
- c. The mobilizer cannot be driven in reverse when towed due to the angle of the trailer tongue when hitched. The trailer tongue was raised approximately 2.5 ft at a 35-deg angle when it was attached to the hitch of the 2.5-ton truck. Backing the mobilizer would result in equipment damage to the hitch or tongue as forces would cause the tongue to fold over.

Implications: The mobilizer may not be suited for cross-country use where rough terrain will be traversed and backing in reverse is a frequent maneuver. Equipment such as the trailer tongue and wheel lugs may be damaged. Crewmen may be injured as they attempt to manually position the mobilizer.

Data: There were six mobilizers (M-720) used for the test; four were dead-lined due to sheared off wheel lug posts on the roadside wheels. Five of the six mobilizers have some damage related to cross-country travel and the weight of the trailer. Crewmen were interviewed and 94% stated that the mobilizer could not be moved manually by the present crews without additional help. The data collectors (97%) and test directorate personnel (92%) agreed. The supervisory personnel stated that a minimum of 5 persons were required to do this task.

Potential Solutions: The internal shelter configuration had all the electronic components positioned on the roadside of the mobilizer. Perhaps the electronic components could be repositioned on both sides of the mobilizer in order to balance the load. However, the only way to avoid exceeding the weight capacity of the mobilizer may be to use a larger-capacity mobilizer.

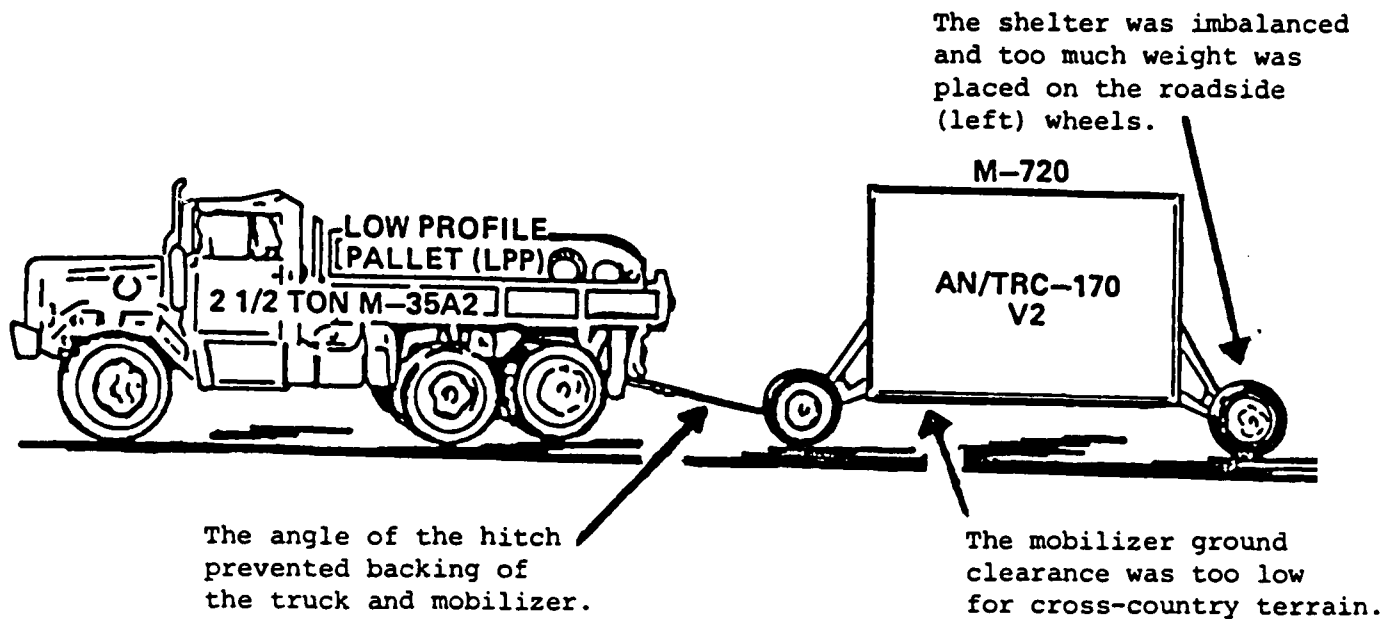

Figure 8. The M-720 mobilizer carrying the S-665 shelter. (The actual configuration of the mobilizer differed slightly from the graphic representation.)

Problem Title: Generator Changeover and Power Load Adjustment

System: V3

MANPRINT Category: Human Factors

Information Sources: On-site observations and test participant comments.

Description of the Problem: There are two 10 kw generators mounted on a single trailer used to support the operation of the V3 system. The generators have two operational problems including:

- a. The generators cannot be switched from one to the other without shutting down the V3 system. The generators need to be switched when fuel is emptied or repairs are required. Once the V3 is shut down, a period of 10 to 15 minutes is required for system warm-up before radio transmissions can be resumed.
- b. Figure 9 shows the V3 main power panel. The generators do not have a built-in capability to adjust for power load variations. When power load variations occur, the operator must see the variation on the power panel voltage meter in the V3 shelter or on the generator and then adjust the generator. Power load variations occur when components in the V3 shelter are turned on or off.

Implications: Interruptions to the radio transmissions for generator switch-over occurred every 6 hrs. Unexpected shutdown for generator failures resulted in lost transmissions. Failure to adjust the generators for power load variations may result in a generator shutdown.

Data: The interruptions to the radio transmissions resulting from the generator shutdowns occurred throughout the test.

Potential Solutions: Provide the generators with switching capability that provides continuous power without power fluctuations. The generators should be able to automatically adjust for load variations.

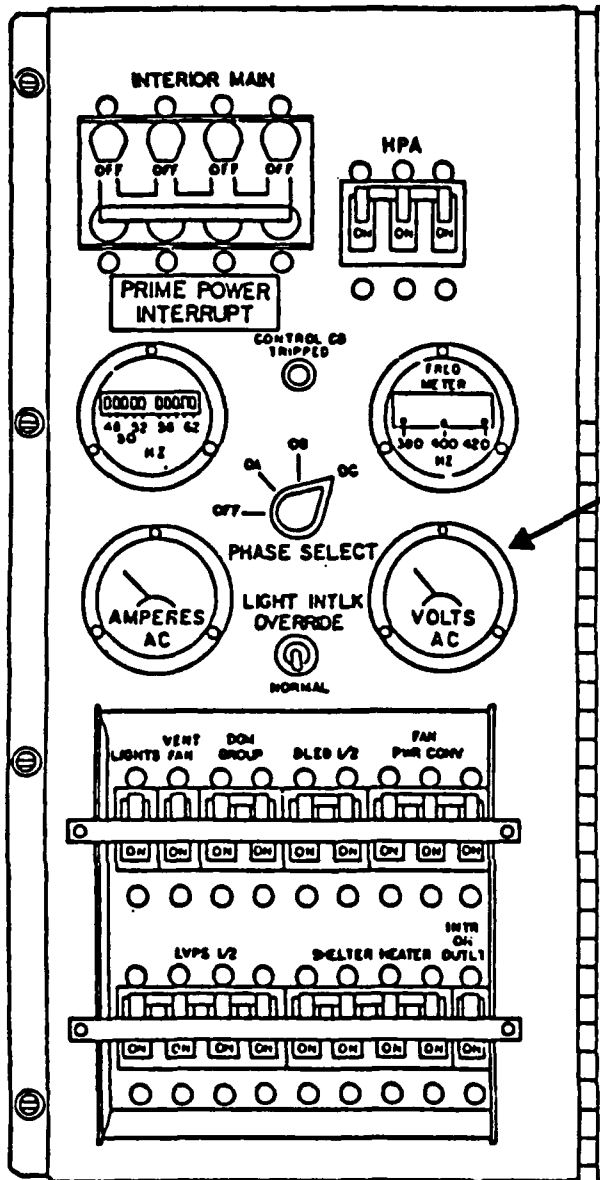

The only indication the crewman had of a power load variation was in the shift of the voltage meter needle.

Figure 9. The main power panel in the V3 shelter.



Problem Title: Noise Levels in the Shelters

System: V2 and V3

MANPRINT Category: Safety

Information Sources: Measures of sound level taken by the MANPRINT specialist; MIL-STD-1472C, paragraphs 5.8.3.1 - 5.8.3.4; MIL-STD-1474B Noise Limits for Army Material.

Description of the Problem: The noise levels within the S-280 and S-250 shelters exceed the minimum ranges for hearing damage. Hearing protection was required during testing for all persons in the shelter during shelter operation.

Implications: The operators and support personnel for the AN/TRC-170 system may suffer hearing loss unless hearing protection becomes a requirement for the fielded V2 and V3 systems.

Data: Measures were taken with shelter door open and closed. The systems were operating in high power mode.

Shelter	Door Open Weighted	Octive Band Frequency (Hertz)									
		31.5	63	125	250	500	1K	2K	4K	8K	16K
V3	82 dB(A)	78	79	84	80	82	81	74	69	75	71
V2	87	90	80	89	79	83	87	78	72	70	71

Shelter	Door Closed	Octive Band Frequency (Hertz)									
		31.5	63	125	250	500	1K	2K	4K	8K	16K
V3	83 dB(A)	82	81	86	80	84	87	81	75	75	69
V2	89	90	80	89	80	87	87	78	73	71	71

Potential Solutions: Hearing protection should be required for V2 and V3 operators and maintainers working in the shelters when the system is fielded. Ideally, noise levels in the shelters should be reduced. Sound-absorbing acoustical materials might be placed on the shelter walls or in the vicinity of noise-producing equipment.

Problem Title: Steps and Handrails on Trucks

System: V2 and V3

MANPRINT Category: Safety

Information Sources: MIL-STD-1472C, paragraphs 5.7.7.3 & 5.12.7.2c; MIL-H-46855B, paragraph 3.2.2.3i; on-site observations.

Description of the Problem: The tailgate steps on the shelter trucks were mounted on the side of the tailgate and did not have handrails. The height of the tailgates (approximately 5 ft) on the trucks requires that steps be emplaced and used. The location of the steps used did not meet MIL standards. Steps should be directly in front of the doors (center of the tailgate) and must have a handrail. The proper steps for access should be part of the fielded system.

Implications: The lack of handrails and side-mounted steps may lead to accidents.

Data: All twenty trucks used in the test were not equipped with safe steps.

Potential Solutions: Appropriate steps and handrails should be provided with all AN/TRC-170 systems.

Problem Title: Loading and Unloading the Low-Profile Pallet

System: V2

MANPRINT Category: Manpower and Safety

Information Sources: Air Force crew size for the AN/TRC-170; the crew size called for in the Technical Manuals; The 26QD6 operators opinions; on-site observations; Lifting and carrying standards from MIL-STD-1472C, paragraphs 5.9.11.3.1 - 5.9.11.3.9.

Description of the Problem: Figure 10 shows the low-profile pallet and its contents. The loading and unloading of the low-profile pallet for the V2 system (9.5 ft) antenna is unsafe to perform by three crewmen (AN/TRC-170 V2 crew size). The weights that must be lifted and carried exceed MIL-STD-1472C maximums for three soldiers. The unit (Heavy Tropo Company) does not have other personnel available (TO&E) to support the crews in the field to assist in lifting material. The system can not be set up with a two-man crew making the system un-emplacable if any crew member is injured or otherwise unavailable. The units may set up in isolated locations and other personnel may not be readily available.

Implications: The crews may suffer injuries such as back strain, muscle strain, contusions, abrasions, or broken bones. The AN/TRC-170(V2) may not be able to complete its mission.

Data: Seventy percent (70%) of the operators reported that it was difficult for three crewmen to lift equipment when loading and unloading the low-profile pallet.

Potential Solutions: The crew size could be increased by the addition of a maintainer (29M or 29S) to add to the number of persons available for loading or unloading. The procedures for the truss assembly might be modified to reduce the weight lifted by crewmen when disassembling the truss on the pallet.

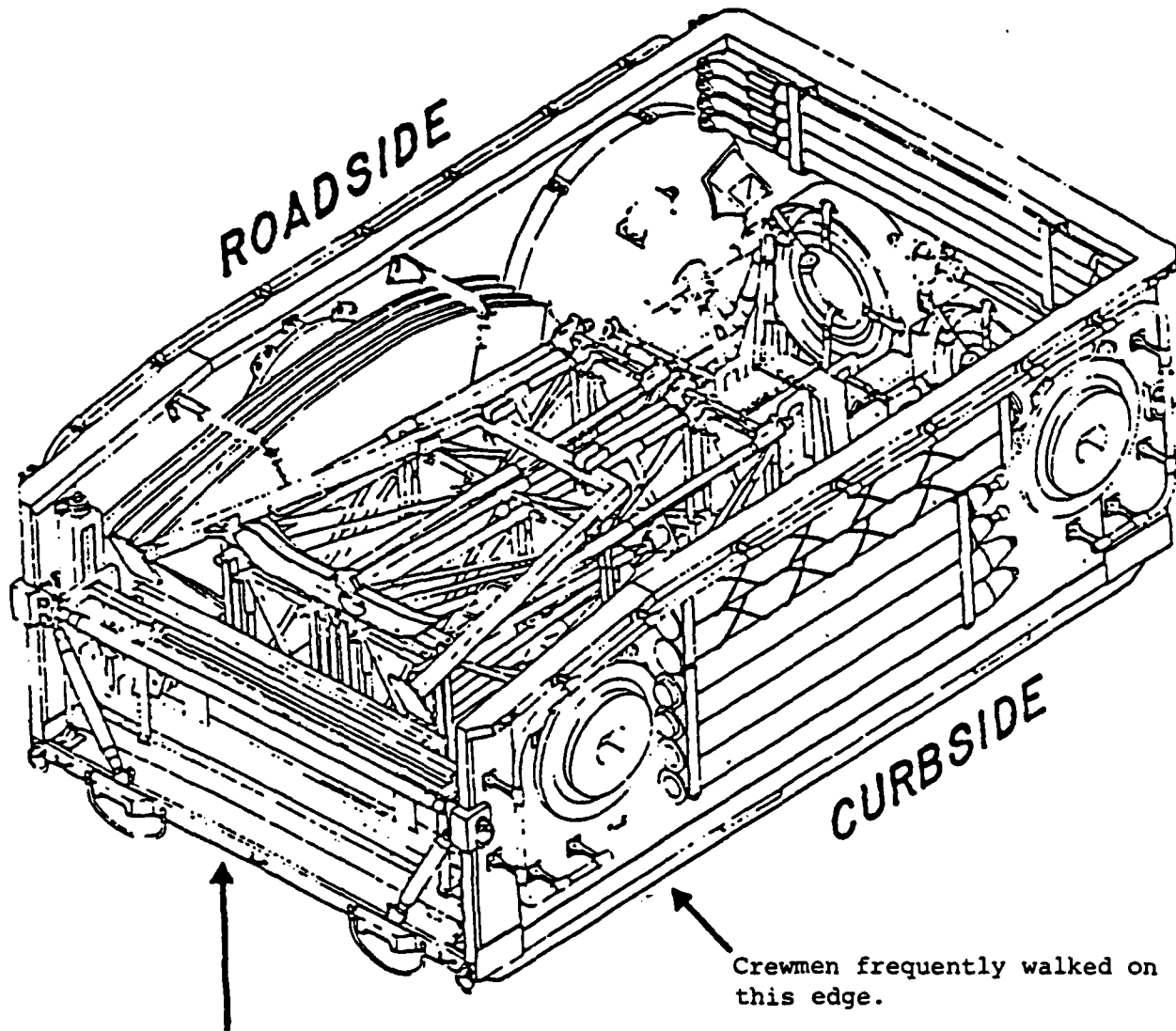

The pallet was approximately five feet above the ground when mounted on the truck bed.

Figure 10. The low-profile pallet that was mounted on a 2.5-ton truck and covered for transport.

Problem Title: Hearing Protection for Pionjar Operators

System: Pionjar

MANPRINT Category: Safety

Information Sources: MIL-STD-1472C, paragraph 5.8.3; on-site observations; MIL-STD-1474B, Noise Limits for Army Materials, paragraph C-7.

Description of the Problem: The measured noise level during operation of the Pionjar was 110+ dB(A). The auditory noise produced by the Pionjar may damage the operators' hearing unless they wear hearing protectors. The Pionjar also produces vibration and, in some cases, the vibration caused the operator to lose ear plugs while operating the Pionjar. The standard ear plugs may not be adequate protection for long-term exposure to the noise.

Implications: Operators may experience loss of hearing acuity and may suffer complete loss of hearing in some frequency ranges.

Data: The noise level was 110+ dB(A) at the Pionjar during drilling. The noise level was 85 dB(A) from a circle 25 ft in diameter around the operating Pionjar.

Potential Solutions: The operators should be issued a better hearing protection device such as ear muff style protectors.

Problem Title: Training for Pionjar Operation

System: Pionjar

MANPRINT Category: Training

Information Sources: AR 70-1, System Acquisition Policy and Procedures; MIL-STD-882B, System Safety Program Requirements; on-site observations.

Description of the Problem: The Pionjar operation, maintenance, and safety procedures are not part of the current Army training system for the 26QD6 MOS crewmen. The Pionjar is a useful tool, but can be dangerous unless it is used properly. The lack of operation and maintenance training for operators may jeopardize their safety and may reduce the useful life of the Pionjar.

Implications: Without proper training, more time may be needed to set anchors. Without maintenance training, the Pionjar may have a shorter duty life. The Pionjar operators may suffer injury.

Data: During the test, six Pionjars were disabled due to improper fuel mixtures. Three Pionjar drive rods were bent during the test. In two cases, system set-up was delayed. Pionjar would not operate due to improper maintenance.

Potential Solutions: Provide training for operators of the Pionjar. The training could be handled at the unit level with TRADOC support. Such support might include preparation of a training video which addresses operation, maintenance and common system failures. Providing commercially prepared canisters of premixed fuel would reduce training requirements and potential problems resulting from incorrect mixtures.

Problem Title: The Allocated Number of Maintainers

System: V2 and V3

MANPRINT Category: Manpower

Information Sources: On-site observations, maintainer and test director comments.

Description of the Problem: The number of maintainers allocated in the TO&E was one for every two V2 and V3 units. However, the units may be separated by 100 miles or more. One maintainer was unable to provide service to two units on a 24-hour operational schedule.

Implications: During combat, it may be impossible for one maintainer to travel the required distances and to be available for 24-hr periods.

Data: During testing, three maintainers per set of units were used.

Potential Solutions: The allocation of maintenance personnel (29M) for this system should be increased to one maintainer for each fielded system. The maintainer could also be used as an additional operator and as crew to augment set-up and tear-down tasking. The type of maintenance actions that crewmen are allowed to perform might be increased.

Problem Title: Waveguide Damage

System: V2 and V3

MANPRINT Category: Human Factors

Information Sources: On-site observations, operator comments, and RAM data.

Description of the Problem: The waveguides, linking the shelters to the antennas, were frequently damaged including:

- a. The male plug alignment and signal pins bend, loosen, and fall out.
- b. The male plug O-ring forming the moisture seal falls out making alignment difficult and risking loss of the O-ring. Figure 11 shows the location of the O-ring and latch device.
- c. The latch securing the male plug to the female socket was difficult to manipulate and had to be forcibly closed. The latch could not be closed by crewmen wearing MOPP NBC gloves.
- d. The protective transport containers for the waveguides used on the V2 system were attached to the pallet. The waveguides had to be carried by crewmen from the pallet to the antenna. The exposed waveguides were often stepped on or collided with objects. Figure 12 shows the protective container, while Figure 13 shows the position of the waveguides when laid out on the ground.

Implications: Several factors contributed to damaging of the waveguides. Damaged waveguides will prevent transmission. Additional replacement waveguides will have to be supplied.

Data: Two-thirds (12) of the waveguides were damaged and unusable at mid-test.

Potential Solutions: The waveguides should be durable enough for the field environment in which they will be used. Operator training should address the sources and prevention of waveguide damage, especially if the design of the waveguides remains unchanged. Two soldiers, rather than one, should be used to support the waveguide when attaching or detaching it to the antenna in order to keep it evenly supported.



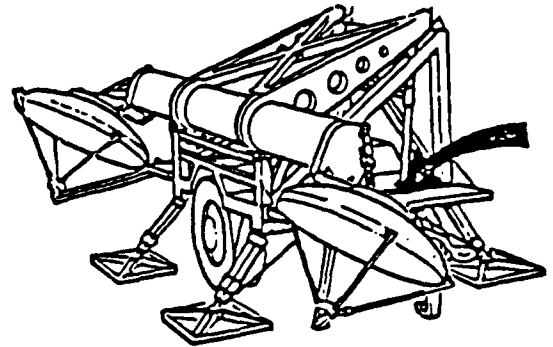
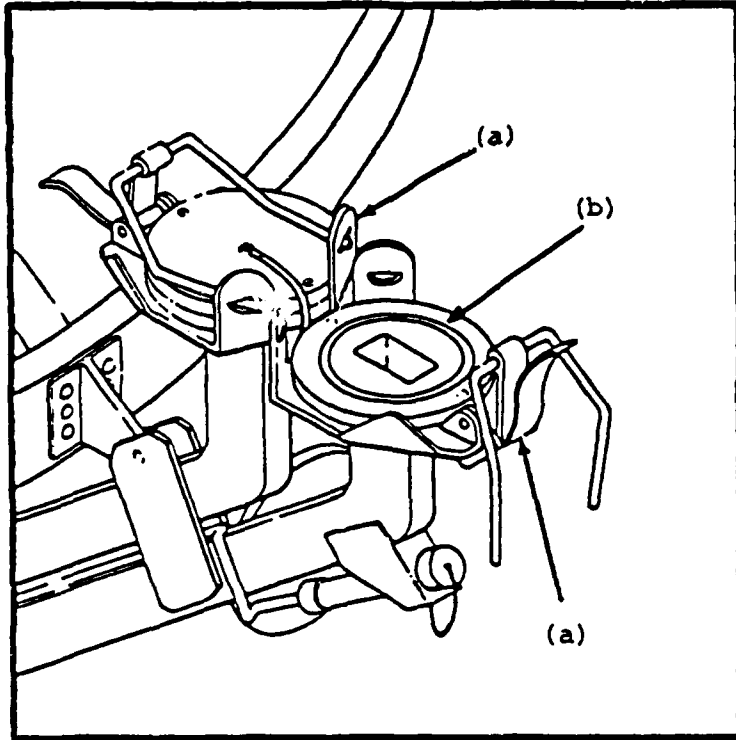

Figure 11. The waveguide latches (a) that were difficult to close and the O-ring (b) that fell out.

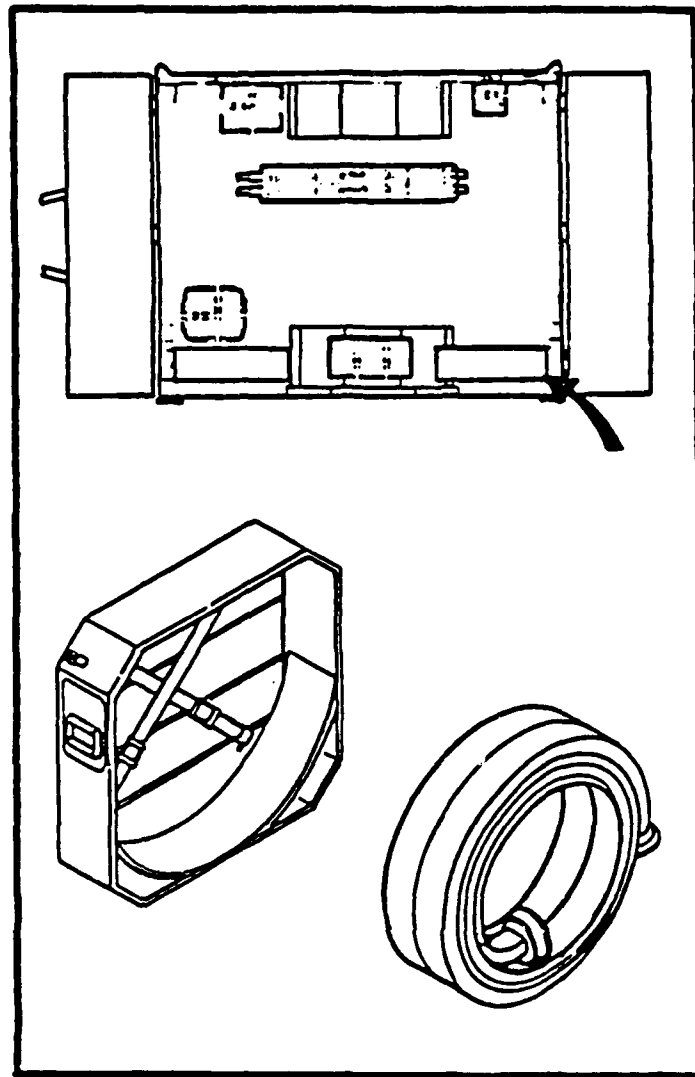

Figure 12. The waveguide protective container and trailer stowage location.

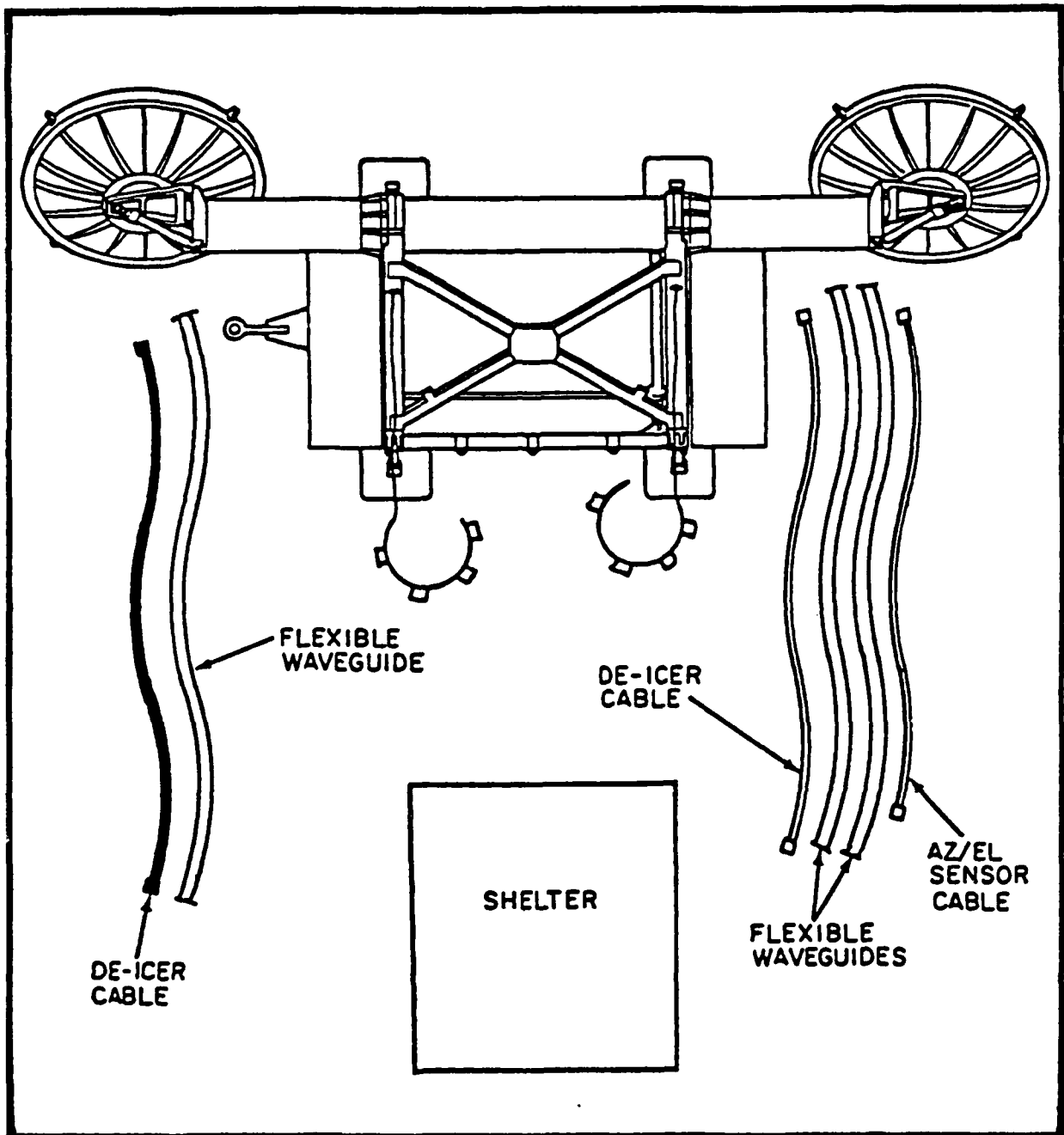

Figure 13. The waveguides and other cables laid out on the ground prior to installation.

Problem Title: Assembly and Disassembly of the Lightning Protection Assembly (LPA)

System: V2 and V3

MANPRINT Category: Manpower and Safety

Information Sources: On-site observations; Opinions of the operators and test directorate personnel; DA Pam 385-16, System Safety Management Guide.

Description of the Problem: Figure 14 shows the LPA configuration that is erected across the top of the antennas. The LPA erection procedures call for four crewmen (crew size is three soldiers). The procedures require one crewman to hold the base plate, one crewman to walk the mast up, and two crewmen to hold the guywires controlling the mast as it rises. The current equipment assembly procedures and the few personnel performing the task may lead to a situation resulting in the collapse of the mast.

Implications: The LPA is erected next to the AN/TRC-170 antennas and shelter. The collapse of the mast might damage the antennas or shelter. The personnel are also endangered by a collapsing LPA mast.

Data: All the test participants (operators, supervisors, data collectors, and test directorate) recommended four-person crews for LPA erection/lowering tasks. Human Factors personnel observed 10 uncontrolled falls of the masts. In one case, an operator had the mast fall onto his shoulder causing a painful injury.

Potential Solutions: If the current LPA masts continue to be used, using a hinged base plate would make erection easier and safer, but for safety would require four man crews for erection. Alternately, consideration should be given to use of telescopic antenna mast sections which are already in the supply system. The training program should demonstrate correct erection/dis-assembly procedures to all 26QD6 personnel during specialty training.

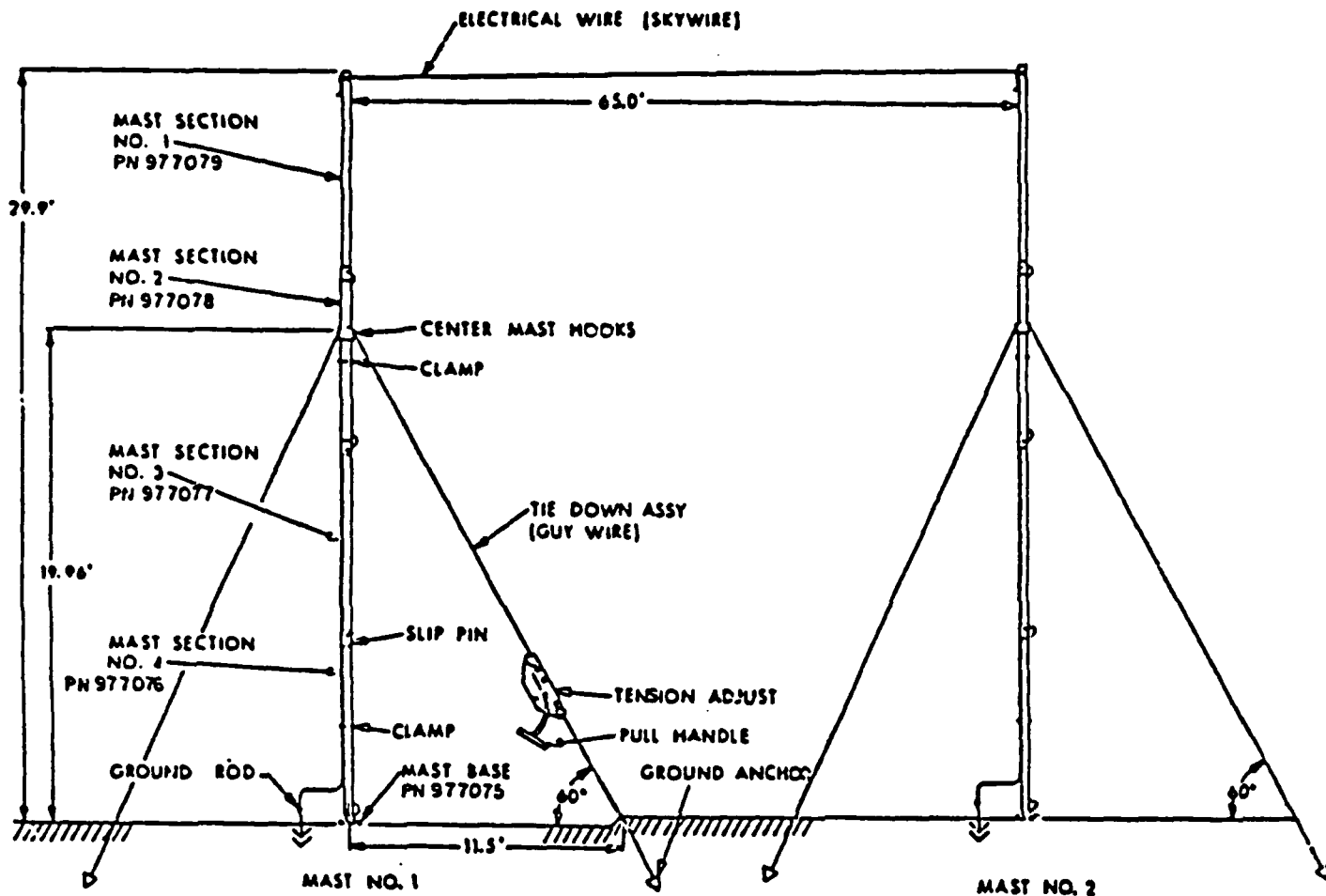

Figure 14. The lightning protection assembly (LPA) that was erected across the top of the antenna structures.

Problem Title: Non-Militarized Pionjar

System: Pionjar

MANPRINT Category: Safety

Information Sources: MIL-STD-1472C, paragraphs 4.9 and 4.10; On-site observations; TECOM TOP 10-2-508, Safety and Health Hazard Evaluation - General Equipment.

Description of the Problem: Figure 15 shows a cut-away view of the Pionjar drive motor. Problems found on the non-militarized Pionjar included:

- a. The Pionjars were not labeled with safety warnings.
- b. Warning labels later supplied to the units did not remain affixed to the Pionjars.
- c. The Pionjar's operation and maintenance manual was not written to military specification and did not contain the appropriate warnings or cautions.
- d. The Pionjars supplied with the system (AN/TRC-170) were not packaged to military specification.
- e. The equipment requires a mixture of gasoline and two cycle engine motor oil for fuel which is not a regularly supplied field item.

Implications: The lack of warnings and cautions may lead to accidents. The Pionjar is currently required to set up the antenna system in support of the AN/TRC-170. The durability and supply characteristics of the Pionjar should be assessed.

Data: Six Pionjars were unavailable due to maintenance problems during the test. The supply system issued improper oil for the oil and gas mixture that is required, causing some Pionjar failures. The crews in some distant sites had to obtain regular gasoline and 2-cycle motor oil from retail stores in order to operate the Pionjar.

Potential Solutions: A separate test of the Pionjar is needed. The device should also be required to meet military packaging and labeling standards. The logistics issue need review.

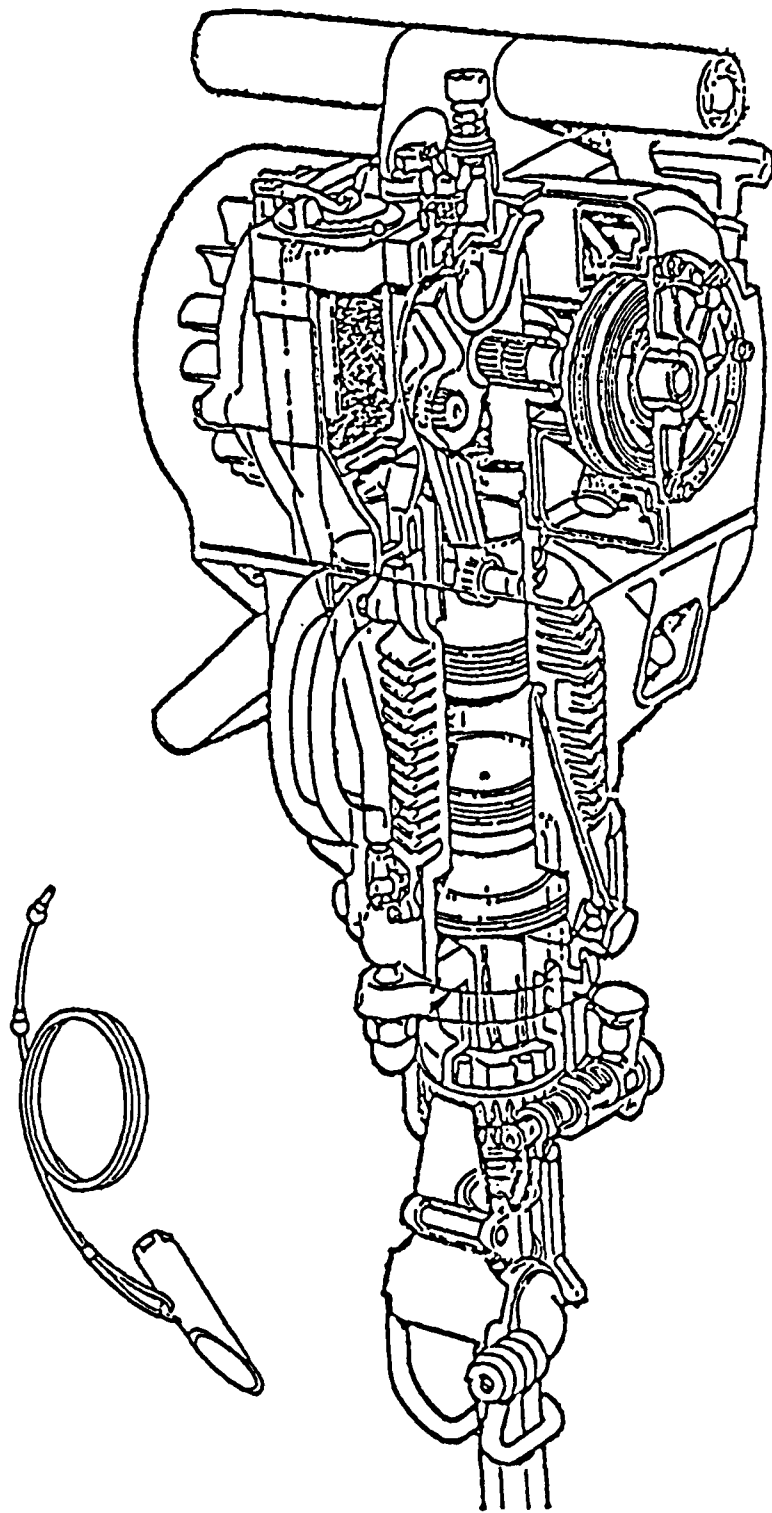

Figure 15. A cut-away view of the Pionjar drive motor and of the duckbill anchor.

Problem Title: Size of the Antenna Anchors

System: V3

MANPRINT Category: Human Factors

Information Sources: On-site observations; Opinions and observations of operators and test directorate personnel. Results of Air Force system tests in 1980.

Description of the Problem: The diameter of the duckbill portion of the anchor is larger than the pilot hole drilled by the Pionjar with the drill bit. The anchor is designed to hold in soft ground, but it is difficult to use in hard or rocky ground. The anchor is not shaped to be driven using the Pionjar and the drive rod often punches through the anchor becoming stuck.

Implications: The use of the anchors is limited and difficult unless they are restricted for use in geographic areas with soft ground. The time required for setting anchors is increased when the anchors become stuck.

Data: The setting of anchors has taken as long as 19 hrs for 12 anchors. All crewmen agree that a more suitable anchor is required to make the system tactically usable. Sixty-three percent (63%) of the operators and field data collectors reported that in a tactical situation, the present anchors should not be used. Four driving rods have been bent and the manhours required to remove them have exceeded 8 hrs per incident.

Potential Solutions: The present anchors could be used in addition to an assortment of sizes to be used depending on soil conditions. The system developer should review the anchors already on the market and find a more usable anchor or set of anchor sizes than the one selected. A less specialized anchor design might reduce the cost of the anchors.



Problem Title: Training Topics for Collective Training

System: V2 and V3

MANPRINT Category: Training

Information Sources: On-site observations; training evaluations.

Description of the Problem: The collective training provided at Keesler AFB lacked several topics or techniques including:

- a. Demonstrations of site emplacement and the locations of equipment for safety and tactical security.
- b. Instruction and examples of radiation hazard zones for microwave antennas.
- c. Practice of equipment assembly and disassembly.
- d. Site camouflage and concealment.
- e. Network and link planning for staff and operations personnel.
- f. Detailed troubleshooting for system operating difficulties and for fault isolation.
- g. Use of the pocket transit for crewmen.
- h. Interfacing the COMSEC device and its operating procedures with the other electronic components. The lockup of the COMSEC orderwire bridge resulted from operators not realizing that the VINCINT device was not in the appropriate status.

Implications: Without the appropriate training, crewmen may emplace the unit creating safety problems such as: personnel walking through microwave hazard zones, placing the stowed fuel too close to the generators, and placing the generators too close to the sleeping areas. The tactical security of the unit could be compromised by improperly concealed equipment, blocked views of enemy approach routes, and blocked evacuation routes. Delays during emplacement may result from difficulties in establishing network links or from time spent troubleshooting difficulties.

Data: Seventy-one percent (71%) of the operators reported that additional collective training was needed.

Potential Solutions: The AN/TRC-170 system involves many emplacement, assembly, and disassembly procedures. The procedures would be best taught through field demonstrations rather than by instruction alone. Training might be facilitated using video or slide tape instruction materials.

Problem Title: No Commander for Second Vehicle in Unit

System: V2 and V3

MANPRINT Category: Manpower

Information Sources: Army regulation and Unit standard operating procedures.

Description of the Problem: The present crew size is three crewmen per system unit. Each system has two vehicles assigned as primary movers. Army regulation and highway safety standards call for two crewmen (driver & assistant driver) for trips of longer than 10 hrs. The unit standard operating procedures require a second person (assistant driver) when the vehicle is towing to act as a ground guide (both vehicles in V2 & V3 are used to tow equipment).

Implications: The peacetime employment of the system will require that additional personnel be supplied by the unit during road march and field exercises. If not corrected, the situation in wartime may be overlooked. Potential loss of the system, due to driver fatigue or accidents related to single driver operation, may result. The crew size places the unit in the position of violating safety rules or not getting the system to the field in a timely manner.

Potential Solutions: The crew size for both systems should be increased to four crewmen, two per vehicle. The fourth crewman does not necessarily have to be from the 26Q MOS. It is recommended that an additional maintainer, such as a 29M or a 29S, be added to each crew solving both the manpower and maintenance allocation problems.

Problem Title: Tactical Manning for Radio Operation and Perimeter Security

System: V2 and V3

MANPRINT Category: Manpower

Information Sources: The opinions of unit supervisory personnel, AN/TRC-170 crews; Test Directorate personnel; on-site observations; Field tactical doctrines.

Description of the Problem: The employment of the AN/TRC-170 systems is going to include situations where one or two systems are emplaced and isolated physically from all other military units. Tactically, the crews must man the radio with at least one person, man a Command Post radio, and provide site/perimeter security 24 hrs a day. There are not enough personnel assigned to the system to accomplish these requirements. If there are two systems, the crew size requirement is for seven crewmen (three in each crew and a supervisor); and if only one unit, the crew size is to be three or four persons depending on the location of the supervisory NCO.

Implications: The crew may suffer fatigue trying to meet all the requirements of a tactical situation operating on a 24-hr basis.

Data: Of the 26QD6 operators interviewed, 83% stated the V2 crew was not large enough in tactical circumstances, and 74% agreed that the V3 crew requirements for the tactical situation was not large enough. The supervisory and planning personnel all (100%) agreed crew size should be increased to meet unit tactical demands. The test directorate were interviewed, and 83% also reported a need for increased crew size. The data collectors were interviewed, and 63% stated that tactical crew should be increased to meet manning requirements.

Potential Solutions: Further study is needed to resolve the issue of crew size. While in theory it could be assumed that site security could be provided by collocated infantry units, such units are not always collocated. The unit TO&E should be increased to provide additional personnel to perform these non-system related tasks. The additional personnel do not have to be 26Q MOS personnel. It is recommended that additional maintenance (29M or 29S) be considered as additions to meet any further validated manpower needs.

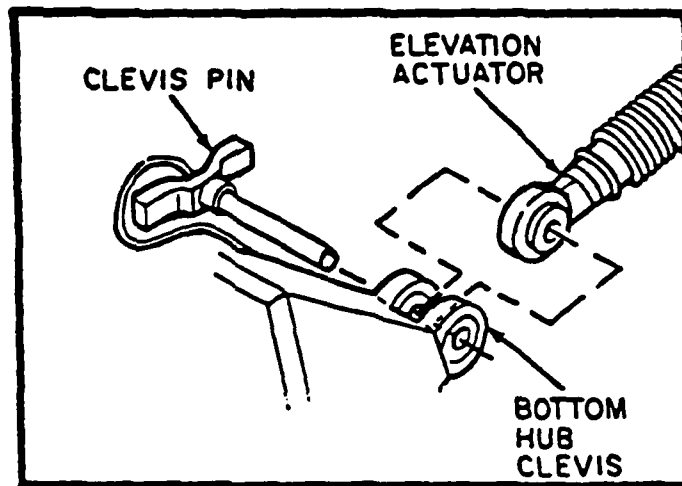

Figure 16. An example of the type of pin that was difficult to insert and remove.

Problem Title: Attachment Pins for the Antennas

System: V2 and V3

MANPRINT Category: Human Factors

Information Sources: On-site observations; Operator opinions and comments.

Description of the Problem: Figure 16 shows the type of clevis pins used to secure and assemble equipment. The clevis attachment pins used on the AN/TRC-170 antennas are difficult to handle. The pins are used to hold the antennas together and to secure antenna parts to the low-profile pallet. The pins fit tightly and are difficult to install and remove. The pins have been damaged by attempts to install or remove them using improper tools such as hammers, rocks, and other objects.

Implications: The pins slow the assembly and disassembly process. There are no replacement pins supplied to the unit. Lost or damaged pins may make assembly or disassembly dangerous or impossible.

Data: Every unit had damaged pins. Replacing the pins was logistically difficult.

Potential Solutions: The pins should be treated with an approved lubricant to control corrosion and facilitate insertion. The holes receiving the pins should be flanged to help insertion/removal. Crewmen suggested that a rubber mallet be issued and used to insert or remove pins.

Problem Title: Binding of the Antenna Rear Truss Clamp

System: V3

MANPRINT Category: Human Factors

Information Sources: On-site observations; Operator comments.

Description of the Problem: Figure 17 shows the rear truss clamp and bearing ball configuration. The rear truss clamp which locks down the bearing ball on the end of the truss assembly binds. The clamp cannot be closed without lifting the loaded base plate, a job that is heavy and dangerous. The problem occurs when the antenna is set to the 15-ft height versus the 10-ft height.

Implications: The operators may be injured an/or the antenna damaged. The rear truss might slip out of the base plate and fall. The antenna would become inoperable due to damage.

Data: The problem has been observed on 5 of the 12 antenna systems in test. The problem was not corrected on all the fielded antennas by the end of the test.

Potential Solutions: The rear clamp assembly needs to be modified. The new antennas in production should be modified prior to fielding.

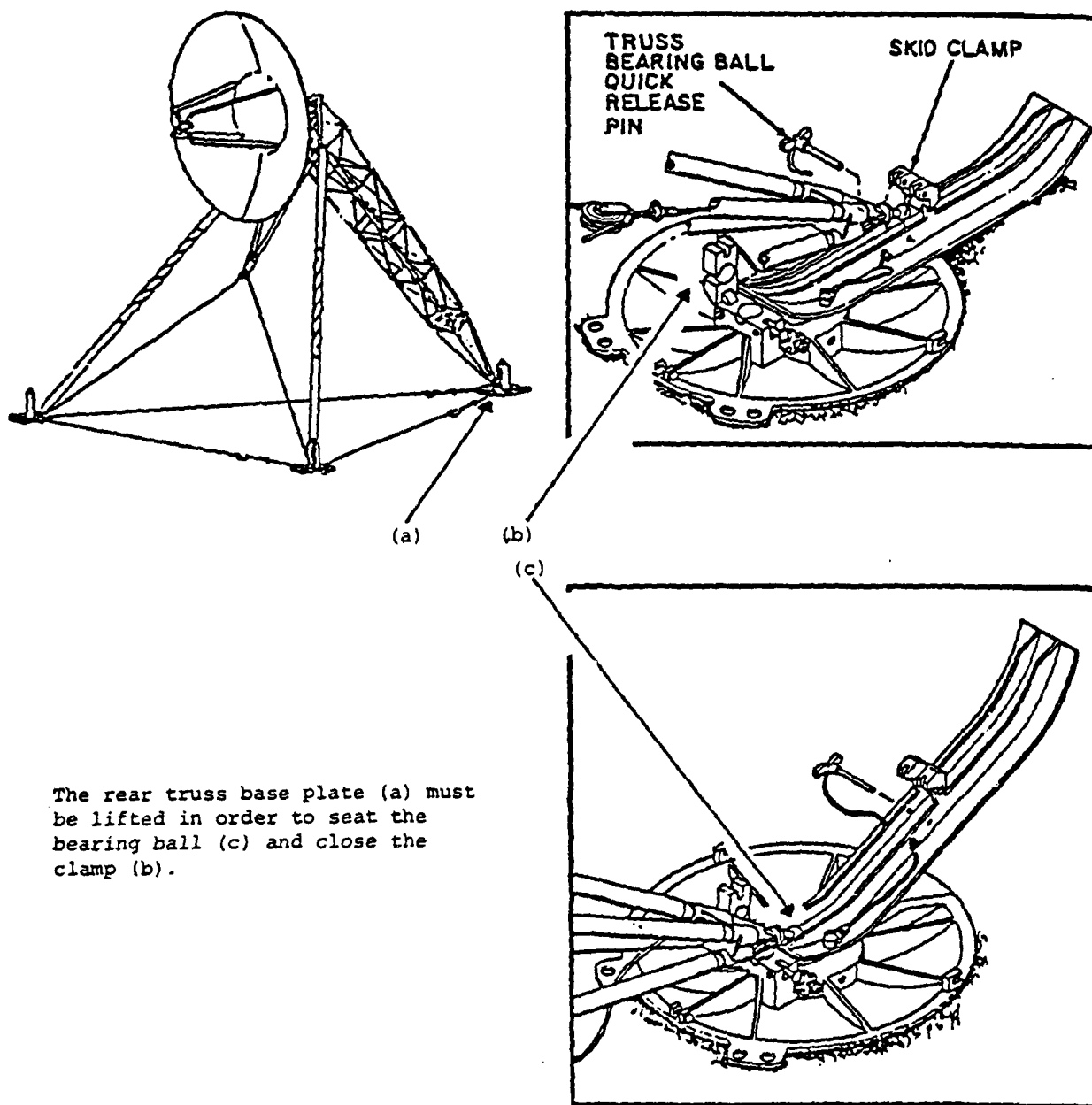

The rear truss base plate (a) must be lifted in order to seat the bearing ball (c) and close the clamp (b).

Figure 17. The 9.5-ft antenna (a), rear truss clamp (b), and bearing ball (c).

Problem Title: Shelter Floor Slip-and-Fall Hazard

System: V2 and V3

MANPRINT Category: Safety

Information Sources: On-site observations; MIL-STD-1472C, paragraph 4.8; AR 385-10 Army Safety Program.

Description of the Problem: The S-280 and S-250 shelter floors do not have non-slip or anti-static surfaces. The shelter floors are painted metal and are dangerous unless surfaced with non-skid material. The electronic components in the shelters are subject to damage by static discharge. The floor protection also needs to include an anti-static surface to prevent damage to electronic components from static discharge.

Implications: Crewmen may be injured in slip-and-fall accidents. Damage to equipment may be caused by falling crewmen striking equipment and by static discharge affecting the electronics.

Data: Twenty percent (20%) of the crewmen reported slipping on the shelter floor when the floor or their boots were wet.

Potential Solutions: The shelters should be equipped with non-skid, anti-static floors or protective rubber mats.



Problem Title: No Ladders for Antenna Assembly and Disassembly

System: V2

MANPRINT Category: Safety

Information Sources: The system PLL; on-site observations; comments of operators and test directorate personnel.

Description of the Problem: Figure 18 shows the type of manipulation task that must be performed on the 9.5-ft antenna. Figure 19 shows the antenna hand crank that is difficult to reach. The assembly of the 9.5-ft antenna has several situations where personnel need to extend their reach. There is no ladder or other approved stand available on the AN/TRC-170. The situations include the following:

- a. Pins for the upper pedal assembly
- b. Support struts for the AZ/EL assembly
- c. Roll yoke adjustment
- d. Messenger cable installation and removal
- e. Adjustment of waveguide connections
- f. Loading/unloading the low-profile pallet.

Implications: The use of field-expedient methods used by crews may involve the use of unstable and dangerous platforms. The antenna structure was not designed for climbing or standing on the cross braces. Equipment damage may result from climbing up the truss assembly.

Data: Sixty-three percent (63%) of the operators reported observing personnel climbing or reaching in a dangerous manner. One operator broke his finger in the process of releasing the support struts for the AZ-EL assembly. Numerous reports were received concerning the dropping of antenna parts while crewmen were reaching and climbing.

Potential Solutions: Provide a stand as standard equipment issue for the AN/TRC-170(V2). It is recommended that at least a 3-ft high stand or ladder be supplied.

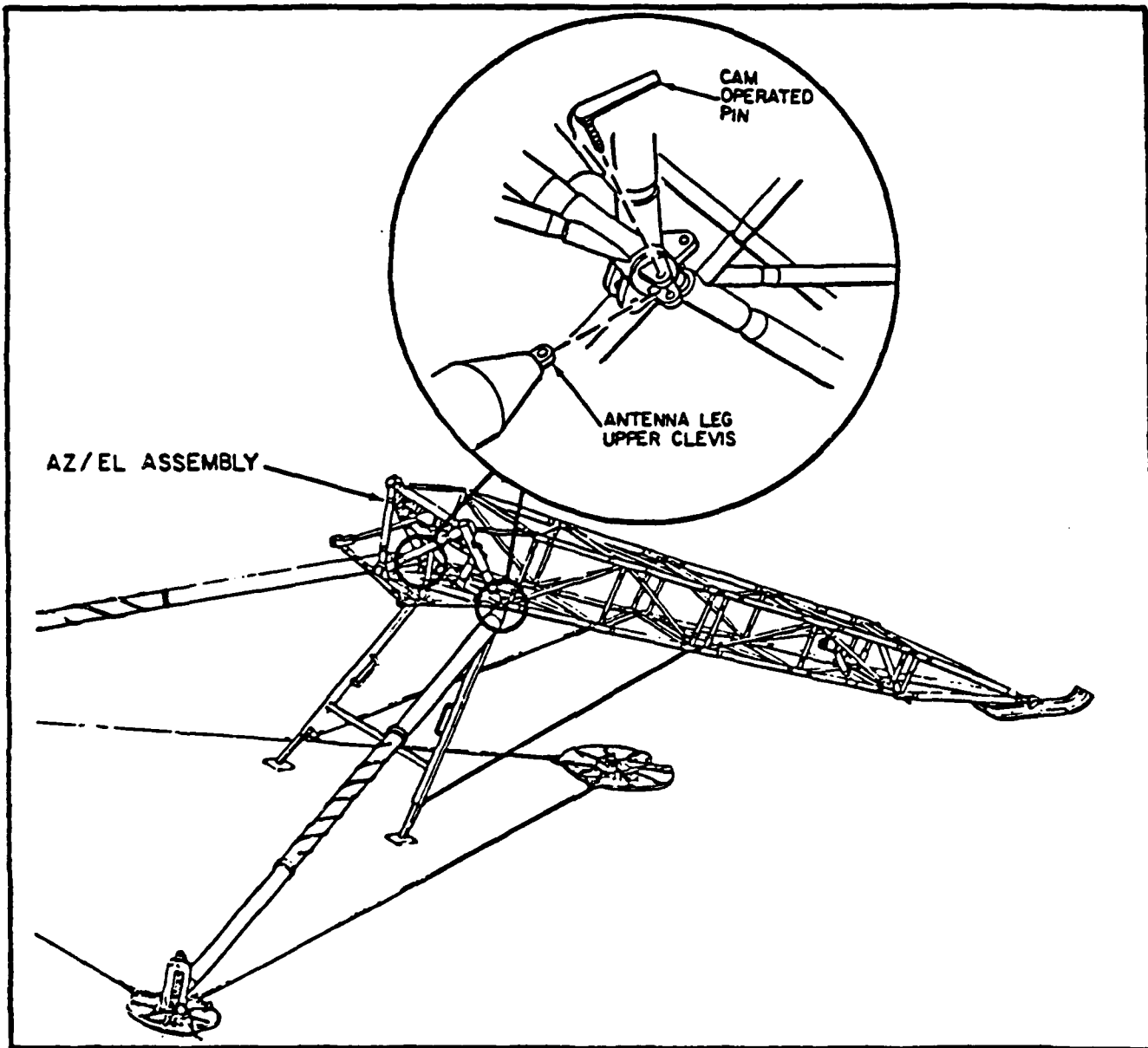

Figure 18. An example of the type of manipulation task that could be performed more rapidly by crewmen using a stepladder or platform.

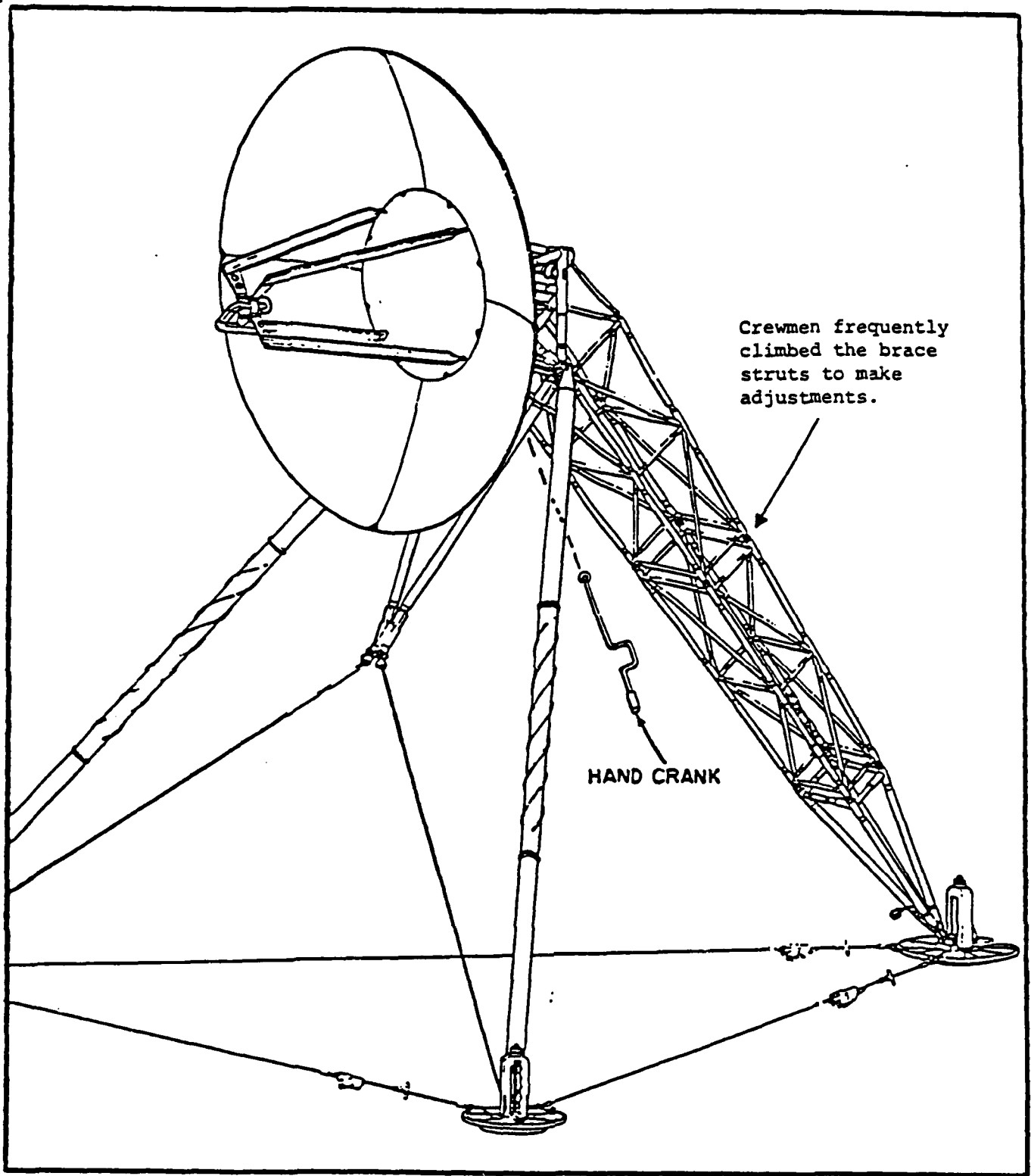

Figure 19. The 9.5-ft. antenna and hand crank that was difficult to use to reach the elevation angle adjustment device.

Problem Title: Maintenance Access to Components

System: V3

MANPRINT Category: Human Factors

Information Sources: MIL-STD-1472C, paragraphs 5.9.3 - 5.9.4; on-site observations; maintainer comments.

Description of the Problem: Maintainers reported that they could not reach component fasteners due to the limited space behind equipment panels. The fasteners required excessive force before they would release from their sockets. Due to the narrow walk space within the shelter, only one maintainer could access components weighing enough to require lifting by two maintainers.

Implications: Performing maintenance is difficult due to space restrictions. Rapid removal and replacement of components may not be possible.

Data: Eighty-three percent (83%) of the operators stated the work and maintenance area in the V3 was too small.

Potential Solutions: The space arrangements of components within the V3 shelter should be reviewed.

Problem Title: Seating in Shelters

System: V2 and V3

MANPRINT Category: Safety

Information Sources: On-site observations.

Description of the Problem: No seating was provided in the shelter for the operator. The operator sits during extended time periods in the shelters. Operators used whatever objects were available (i.e., water coolers, Pionjar box, folding chairs, etc.).

Implications: The operators will use what is available if seating is not provided. This increases the potential for accidents causing injury to operators and damage to equipment. The potential for crew back strain or fatigue is also increased without proper seating.

Data: Since seating was unavailable, all operators in the test used make-shift seating.

Potential Solutions: A fold-down or fixed, padded seat with a back rest should be provided in all shelters.

Problem Title: Accessory Kit Location on Low-Profile Pallet

System: V2 and V3

MANPRINT Category: Human Factors

Information Sources: AN/TRC-170 TM for the V2 system; on-site observations; Operator comments.

Description of the Problem: Figure 20 shows the location of the accessory kit on the low-profile pallet. The location of the accessory kit, which includes the pocket transit on the low-profile pallet, is located on the bottom of the pallet beneath the antenna truss structures. The pocket transit is the first item needed for site layout. The crew must remove the canvas cover from the pallet and push antenna parts out of the way to retrieve the kit.

Implications: The emplacement of the antenna is delayed by the time required to obtain the pocket transit. Crew members must assume awkward and precarious positions to get to the accessory kit. Crew injury is possible. The crew may choose to not use the compass and this may lead to alignment errors.

Data: Fifty-one percent (51%) of all the operators recommended that the location of the accessory kit be changed. Seventy-five percent (75%) of the crews moved the kit to either the truck cab or the shelter by the midpoint of the test without the direction of senior test participants.

Potential Solutions: The accessory kit should be placed in the shelter near the door or in the truck cab area for easy access.

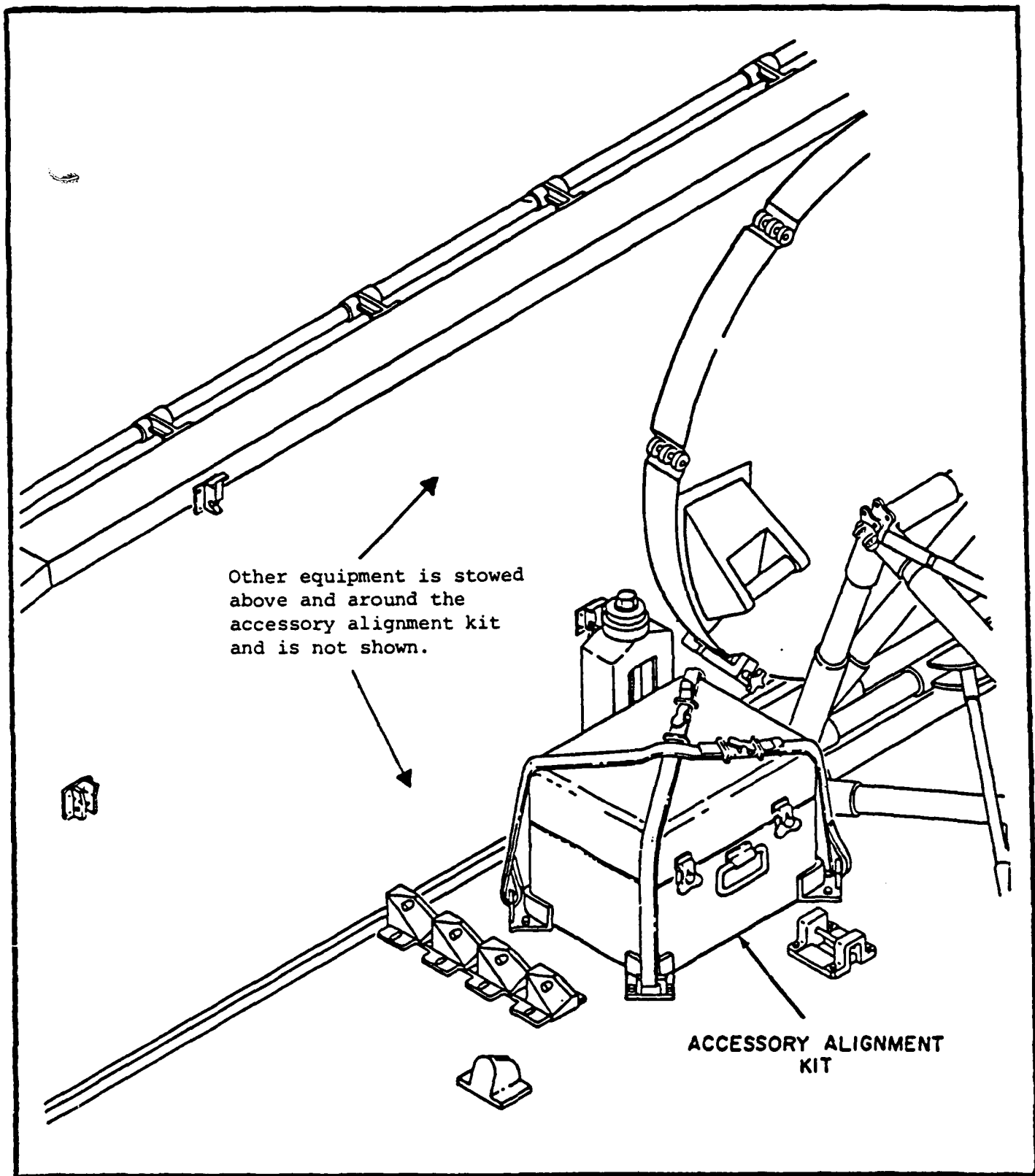

Figure 20. The interior of the low-profile pallet showing the location of the accessory alignment kit.

Problem Title: Walk Space for Loading and Unloading the Low-Profile Pallet

System: V2

MANPRINT Category: Safety

Information Sources: MIL-STD-1472C, paragraphs 4.4g and 4.8; on-site observations; AR 385-16, System Safety Engineering and Management.

Description of the Problem: Figure 21 shows the low-profile pallet secured for transport. Crewmen must walk on the outside edge (3-in width) of the low-profile pallet in order to remove the canvas and ropes. Crew members must assume unsafe positions when removing the canvas cover and retrieving the accessory kit.

Implications: The crews will be subject to slip-and-fall accidents.

Data: Seventy percent (70%) of the crewmen reported that it was difficult for three crewmen to load and unload the low-profile pallet.

Potential Solutions: The canvas cover over the low-profile pallet could be provided with a drawstring arrangement so that personnel would not have to climb the side of the truck. The load on the low-profile pallet should be redistributed to facilitate loading and unloading, and consideration should be given to moving some of the load to the shelter.



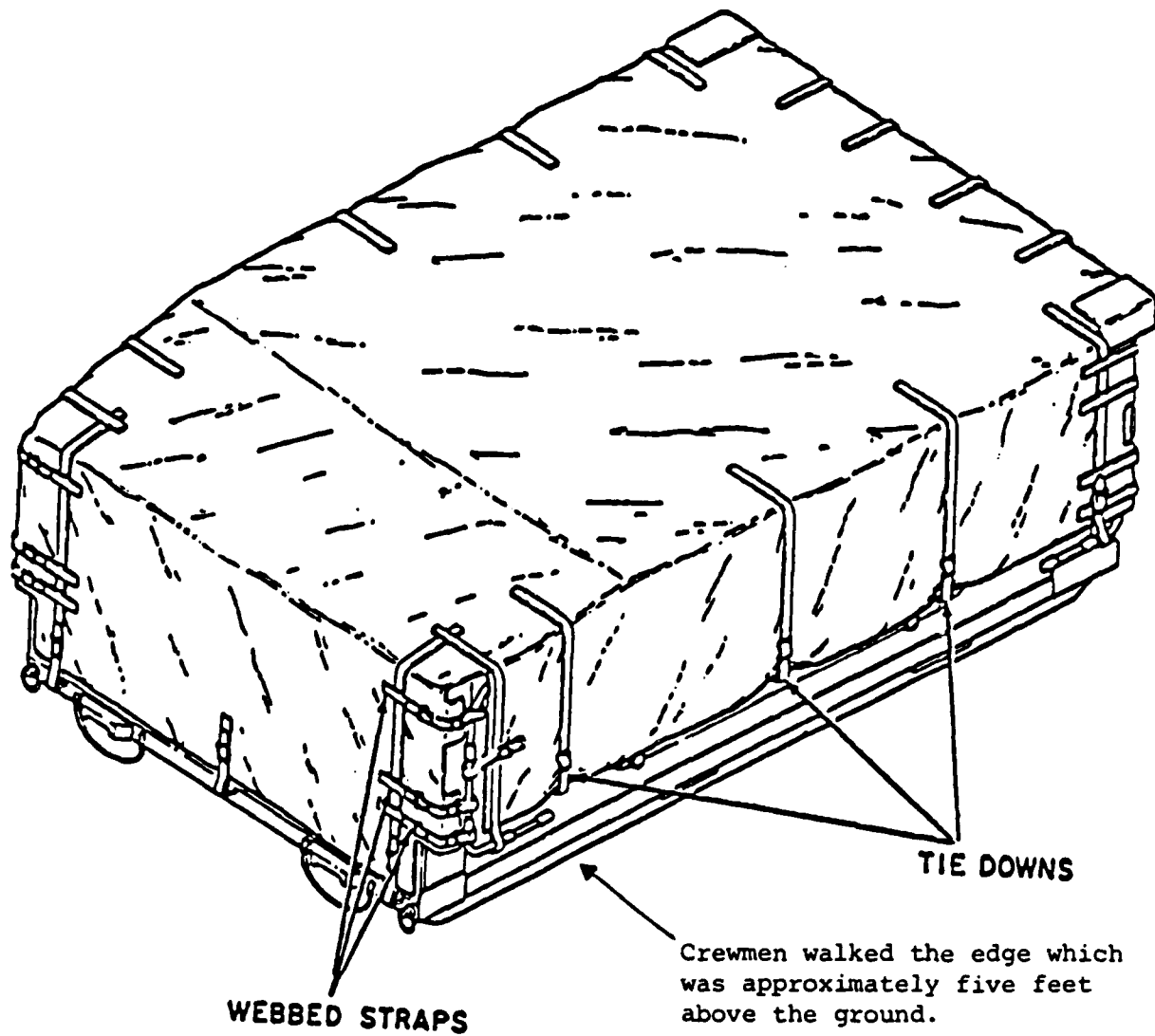

Figure 21. The low-profile pallet which was mounted on a 2.5-ton truck.

## Task Performance Measures

System performance criteria for the AN/TRC-170 V2 and V3 systems included:

1. V2 system emplacement (set-up) time was not to exceed 240 minutes for a combination of all tasks, except LPA erection and anchors.
2. V2 system displacement (tear-down) time was not to exceed 120 minutes.
3. V3 system emplacement (set-up) time was not to exceed 120 minutes.
4. V3 system displacement (tear-down) time was not specified, but would be specified on future tests based on the FOT&E results.

Crew task performance times are shown in the following series of tables. Table 5 lists the V2 system task set-up times for each of the tasks performed. The table also shows the tasks performed by 3- and 4-man crews. Table 6 lists the V2 system tasks tear-down times for each of the tasks performed by 3- and 4-man crews. Table 7 lists the V3 system task set-up times for each of the tasks performed by 3- and 4-man crews. Table 8 lists the V3 system task tear-down times performed by 3- and 4-man crews. The tasks performance times were collected on a sample of occurrences that could be attended by the MANPRINT specialist. The data was collected during Phase III of the test, after crews had the experience of performing the tasks during pilot test and Phase II record testing. The number of observations for each task are shown in the tables. Several tasks were not performed by 4-man crews.

Table 5

Task Performance Time (in minutes) for V2 Set Up by Number of Persons Performing the Task

Task	Number Persons	Number of Obs.	Mean	SD <sup>a</sup>	Max.	Min.
Azimuth Stake Out <sup>b</sup>	3	15	12.5	14.7	62	2
Antenna Base & LPA Stake Out <sup>b</sup>	3	11	19.5	15.1	45	3
Transit Frame Removal	3	22	2.7	1.6	8	1
	4	6	2.0	1.3	4	1
Truss Removal	3	22	3.0	1.7	8	1
	4	7	2.1	1.3	5	1
Antenna Anchors <sup>b</sup>	3	10	133.4	112.1	336	10
	4	1	57.0	0.0	57	57
Off-Load Pallet <sup>b</sup>	3	27	59.4	61.3	197	10
	4	5	16.8	6.6	25	11
Base Plate Install Antenna #1	3	15	14.4	15.6	67	4
	4	4	3.5	2.4	7	2
Base Plate Install Antenna #2	3	12	11.3	8.7	32	4
	4	2	2.0	0.0	2	2
Secure Antenna Legs Antenna #1	3	25	7.6	9.0	32	1
	4	3	3.3	0.6	4	3
Secure Antenna Legs Antenna #2	3	21	9.3	9.6	32	1
	4	3	5.3	4.2	10	2
Install AZ-EL Antenna #1	3	23	5.2	6.3	32	1
	4	4	2.3	1.3	4	1
Install AZ-EL Antenna #2	3	18	5.2	3.9	17	1
	4	4	2.5	2.4	6	1
Install Reflector Hub Antenna #1	3	28	4.9	5.3	30	1
	4	3	3.0	1.0	4	2
Install Reflector Hub Antenna #2	3	28	3.9	1.6	7	2
	4	3	2.3	1.2	3	1

<sup>a</sup>SD = Standard Deviation.

<sup>b</sup>Tasks crewmen found most difficult to perform.

Table 5 (Cont'd.)

Task Performance Time (in minutes) for V2 Set Up by Number of Persons Performing the Task

Task	Number Persons	Number of Obs.	Mean	SD <sup>a</sup>	Max.	Min.
Install Upper Pedals Antenna #1	3 4	24 2	6.6 5.5	6.9 3.5	29 8	1 3
Install Upper Pedals Antenna #2	3 4	28 2	4.4 12.5	3.0 13.4	13 22	1 3
Install Roll Yoke Struts Antenna #1	3 4	16 2	4.8 4.0	3.4 1.4	15 5	1 3
Install Roll Yoke Struts Antenna #2	3 4	17 1	5.0 1.0	3.0 0.0	11 1	1 1
Attach Waveguides Antenna #1	3 4	13 1	6.7 7.0	3.6 0.0	15 7	2 7
Attach Waveguides Antenna #2	3	14	6.9	3.1	12	2
Antenna #1 Erection	3 4	28 1	14.7 21.0	9.7 0.0	54 21	3 21
Antenna #2 Erection	3 4	24 1	11.8 7.0	7.7 0.0	34 7	4 7
LPA Erection <sup>c</sup>	3 4	18 22	60.7 44.2	48.3 32.2	183 126	19 13
Shelter External <sup>b</sup>	3 4	13 7	71.8 12.3	96.4 8.4	270 29	3 4
Shelter Internal <sup>b</sup>	3	8	38.1	40.1	125	8
Klystron Adjustment <sup>b</sup>	3	3	31.0	25.7	51	2
Antenna Alignment <sup>b</sup>	3	5	65.2	46.4	115	12

<sup>a</sup> SD = Standard Deviation.

<sup>b</sup> Tasks crewmen found most difficult to perform.

<sup>c</sup> LPA erection was not included in the system emplacement criteria.

Table 6

Task Performance Time (in minutes) for V2 Tear Down  
by Number of Persons Performing the Task

Task	Number Persons	Number Obs.	Mean	SD <sup>a</sup>	Max.	Min.
LPA Disassembly	3	19	14.8	d	30	7
	4	25	14.1	d	33	8
	c	44	14.4	5.7	33	7
Lowering Antenna #1	3	27	15.2	d	35	4
	4	8	11.6	d	24	2
	c	44	12.8	11.9	73	2
Antenna #1 Disassembly	3	33	23.9	d	67	8
	4	8	24.2	d	39	15
	c	44	23.0	10.7	67	8
Lowering Antenna #2	3	30	10.0	d	20	3
	4	7	8.4	d	12	4
	c	44	9.9	5.2	23	3
Antenna #2 Disassembly	3	32	21.5	d	36	8
	4	9	21.3	d	33	9
	c	44	21.5	8.0	40	8
Packing Pallet <sup>b</sup>	3	31	61.8	d	135	15
	4	11	54.0	d	90	39
	c	44	61.4	30.1	135	15

a SD = standard deviation.

b Tasks crewmen found most difficult to perform.

c Data totalled over all crew sizes observed.

d Standard deviations were computed only across all crew sizes.

Table 7

Task Performance Time (in minutes) for V3 Set Up by Number of Persons Performing the Task

Task	Number Persons	Number of Obs.	Mean	SD <sup>a</sup>	Max.	Min.
Azimuth Stake Out <sup>b</sup>	3	10	9.8	6.7	20	1
Trailer/Shelter Placement On-Site <sup>b</sup>	3	22	21.6	25.0	103	2
Off-Load Trailer <sup>b</sup>	3	25	24.2	28.8	153	4
	4	1	12.0	0.0	12	12
Attach Extension Tubes	3	24	5.7	3.0	15	2
	4	2	2.0	0.0	2	2
Attach Reflectors	3	22	7.2	6.4	27	2
	4	2	2.5	0.7	3	2
Attach Waveguides	3	22	10.2	8.3	41	3
	4	1	3.0	0.0	3	3
Antenna Erection	3	8	9.1	3.4	15	6
LPA Erection <sup>c</sup>	3	8	49.5	38.1	124	15
	4	20	46.3	27.9	124	10
Shelter External <sup>b</sup>	3	12	29.1	15.3	59	10
Shelter Internal <sup>b</sup>	3	2	20.0	0.0	20	20
Klystron Adjustment	2	4	4.7	4.9	12	1
Antenna Alignment <sup>b</sup>	3	3	36.0	42.6	85	8

<sup>a</sup> SD = Standard Deviation.

<sup>b</sup> Tasks crewmen found most difficult to perform.

<sup>c</sup> LPA erection was not included in the system emplacement criteria.

Table 8

Task Performance Time (in minutes) for V3 Tear Down  
by Number of Persons Performing the Task

Task	Number Persons	Number Obs.	Mean	SD <sup>a</sup>	Max.	Min.
LPA Disassembly	3	10	16.8	c	25	6
	4	21	18.0	c	55	7
	b	32	16.8	10.6	55	6
Lowering Antennas	3	10	9.7	c	23	5
	b	32	8.4	4.9	23	5
Remove & Store Extension Tubes	3	19	10.3	c	50	4
	b	32	9.8	8.5	50	4
Remove & Store Waveguides	3	15	12.9	c	39	3
	b	32	11.9	9.7	39	3
Load Trailer	3	27	20.0	c	44	9
	b	32	21.3	10.3	46	9

a SD = standard deviation.

b Data totalled over all crew sizes.

c Standard deviations computed only across all crew sizes.

V2 system tasks that were the most time consuming and difficult to perform included:

1. Emplacement:

- a. Azimuth stake out. The task required crewmen to climb into the low-profile pallet in order to obtain the M2 compass in the accessory kit. Moreover, crewmen had to measure and record azimuth.
- b. Antenna base and LPA stake out. The proper position for the antenna bases and place settings for the LPA had to be determined based on the azimuth stakes. The antenna base positions were often placed using "eye-ball" estimations and later adjusted as necessary.
- c. Anchor drilling and setting. Drilling anchor holes and setting the duckbill anchors using the Pionjar drill involved several problems discussed in previous sections. Anchor holes drilled in hard, rocky terrain would not receive the anchors. The hollow anchors driven into the holes using the Pionjar would bind in the narrow holes. The Pionjar drill rod would puncture the top of the anchor preventing further setting of the anchor. The drill rod was also difficult to remove once the rod penetrated the top of the anchor.
- d. Off loading the low profile pallet. The equipment for assembling of the antenna was kept on the low-profile pallet. The emplacement had to be unpinned or unstrapped and lowered to the ground. Much of the equipment was awkward and heavy to lift.
- e. Shelter external set up. Many lines and wires must be connected to the shelter receptacles, such as the generator cables, the waveguides, de-icing cables, etc. The receptacles must be uncapped. Several of the lines must be screwed or latched into place. The waveguide latches were especially difficult to latch.
- f. Shelter internal set up. Stowed BII and other shelter equipment must be removed from the shelter before the equipment can be powered up and checked out. The task is also dependent on the readiness and operation of the generators.
- g. Klystron adjustment. The klystron must be calibrated and adjusted to the proper power level setting. The fine tuning of the klystron requires repeated attempts. The klystron also requires about 10 minutes to warm up.
- h. Antenna alignment. Antenna alignment usually requires several trials to adjust the antenna. The alignment cannot be performed until all other tasks are completed. The adjustments continue until the signal reception is maximized. Making adjustments may also include retaking azimuth readings.



## 2. Displacement:

Packing the low-profile pallet. The task of packing the low-profile pallet was difficult due to the amount of equipment lifted, positioned, and secured into its stowage place. Two problems discussed in earlier sections included the limited walkspace on the pallet and the pins that were difficult to manipulate.

V3 system tasks that were the most time consuming and difficult to perform included:

### 1. Emplacement:

- a. Azimuth stake out. The task is the same as the task performed for the V2 system.
- b. Trailer and shelter placement on-site. Aligning the antenna lengthwise and backing the shelter into the proper position from the antenna often required several adjustments, especially on rough terrain.
- c. Off-loading the trailer. Equipment is packed very tightly into the trailer. The unloaded equipment clutters the ground and slows crewmen movements.
- d. Shelter external set up. The task is the same as the task performed for the V2 system.
- e. Shelter internal set up. The task is the same as the task performed for the V2 system.
- f. Antenna alignment. The task is the same as the task performed for the V2 system.

### 2. Displacement:

The crewmen task performance times for tear down of the V3 system appeared reasonable and lasted approximately one hour.

The emplacement of the lightning protection assembly (LPA) was a time-consuming task that was not included in the V2 or V3 systems criteria. The LPA was described in the previous section of the report. The LPA could be erected after the AN/TRC-170 was emplaced and operating. The most difficult subtask was raising the LPA mast by one crewman while two other crewmen handled two of the three guywires. Work went slowly, for the mast was difficult to raise in a stable, safe fashion. Once the two masts were in place, the overhead lightning cable was raised. Raising the cable progressed slowly as crewmen were careful not to entangle the cable on other antenna equipment.

The system emplacement criteria of 240 minutes for the V2 system and 120 minutes for the V3 system were more important to the test directorate than displacement criteria. Emplacement times directly effect how rapidly communications networks can be established. Review of start and stop times for each critical task in conjunction with each other task on the day of emplacement indicated that these were occasions where the order of task performed varied. Several tasks were performed during overlapping time periods and there were large gaps in the times between consecutive tasks. Documented data immediately available do not reflect the causes for these breaks; however, one of the MANPRINT specialists frequently on site during the FOT&E has indicated that data collectors did not document when or why operators were interrupted in the performance of a task. Only start and stop times were recorded. For example if a task was begun, and soldiers stopped for a "chow break," the total elapsed time for this task included the "chow time". If soldier began a task late at night but stopped to sleep, elapsed time recorded reflected this "sleep" time. Detailed data to document the "whys" of these breaks does exist in logs of SYSCOM--a control center which monitored and interfaced between operators at all sites throughout the FOT&E. It would be possible, but extremely difficult to collate SYSCOM logs with Data Collectors time data. Such collations would have to be done manually on a case-by-case basis for a total of 76 emplacements performed during the FOT&E. SYSCOM Logs associated with this FOT&E are not in the possession of ARI; if they continue to exist they are probably archived at Fort Huachuca. In order to provide some perspective on the characteristics of these data it is important to understand that while there is considerable dependency among tasks performed at any one site, establishment of communications with another site depends on the coordinated alignment of antennas at a second site. If operators at one site were at "chow", "sleeping" or had equipment malfunction, the final emplacement critical task--antenna alignment--would be delayed.

With such data, it is difficult to state without ambiguity whether the time criteria for emplacement were met. In order to address this question, the Data Collectors' start and stop times for each critical task were reworked. Table 9 summarizes the results of these analyses. As noted above, emplacement involves all tasks except Antenna Anchoring and LPA erection. When asking whether emplacement can take place within the criterial time periods, the most direct measure is to examine is the "elapsed time" between the start of the first emplacement task--generally Azumuth Stake out--and the stop time for the last emplacement task--generally Antenna Alignment. Mean times for all emplacements and the proportion of emplacements performed within the criterial periods (when all criteria emplacement tasks were performed by at most three operators and when one or more of these tasks involved a fourth operator) are shown in Table 9.

With the previous discussion as a backdrop, it is not surprising that the proportions using the elapsed time measure are low and mean times generally exceed the criterial limits by a wide margin. In order to obtain a more refined estimate of emplacement successes and performance times, a second measure--"time in critical task"--was compiled. Basically this measure begins with the "elapsed time" and removes all time periods in which clearly there is no activity on any of the critical emplacement tasks. This latter measure removes much of the dependency of emplacement times which are due to

inactivity at a second site. To the extent tasks begun were completed before soldiers went to "chow" or "sleep", this measure provides a better estimate of emplacement time. Using this better measure, it is quite clear that the proportions of critical emplacement times appear to be considerably larger than with the "elapsed time" measure, and the mean performance times are about fifty percent smaller. The AN/TRC-170 units were originally designed to be operated by 4-man crews. The Army, in an effort to reduce manpower, tested the unit with 3-man crews. While there is some indication that a larger number of operators can meet the emplacement criteria better and somewhat more quickly, the number of observations available upon which to base such a conclusion is relatively small. Tables 5 and 7 provide added indication of specific tasks for which more favorable critical task performance times was obtained with more operators. These data seem to indicate that in order to assess the system emplacement criteria question, an in-depth investigation of the time-consuming tasks and 4-man crews is required. In order to reduce the time-consuming task times, it may be necessary to streamline procedures, modify equipment for materials handling, and examine training. It should be noted that the task times were sampled during Phase III when crewmen were most experienced and practiced. Thus, improved training may offer little opportunity to improve crew task performance time. Moreover, several problems were discussed earlier that directly impact on the task times, such as the lack of walkways on the low-profile pallet, difficulties using the Pionjar to set duckbill anchors, and cramped stowage space for equipment. Having 4-man crews man the AN/TRC-170 would have several other benefits beyond shortening task performance times. The additional benefits include: a driver and commander for each vehicle, an additional crewman for 24-hour operations, and additional crewman for perimeter security.

In addition to the items suggested above for further study, there is a more general concern about testing--fidelity to the real world. There appears to be a tendency within the test community for tests to be designed to support the emerging system. Specifically tests are designed to test the operational characteristics of the system--in a "test tube"--rather than in the real world environment for which the system was designed. Results of analyses presented in Table 9 suggest that more attention was given to soldier comfort--sleeping and eating--than might actually occur in a war time environment. If this test were conducted to place priority on making the system operational within the time criteria established, it is more likely that measures of "elapsed time" would coincide with "time in critical task". Perhaps of greater importance, the manpower requirements for "on-task" and "off-task" operation of the system would be more adequately addressed. It is strongly recommended that as part of any in-depth investigation suggested above, the design should incorporate a level of fidelity which permits manpower requirements to be more accurately assessed.

Table 9

Proportion of Criterial Emplacements and Mean Employment Times with Two Measures: Elapsed Time and Time in Criterial Tasks

<u>EMPLACEMENT TIMES</u>								
	n	Max No/Task	Elapsed Time			Time in Criterial Tasks		
			Proportion	Mean	SD	Proportion	Mean	SD
V2	3	3	.12 (4)	579.61	485.52	.70 (23)	224.15	129.31
	11	4	.18 (2)	638.45	460.33	.73 (8)	194.82	64.82
TOTAL	44		.14 (16)	594.32	474.73	.70 (31)	216.82	116.56
<hr/>								
	30	3	.03 (1)	318.43	188.42	.50 (15)	156.47	102.90
V3	2	4	1.00 (2)	105.00	0.00	1.00 (2)	72.50	.71
TOTAL	32		.90 (3)	305.09	189.65	.53 (17)	151.22	101.64

Note 1. Proportion is the proportion of times the emplacement tasks were performed within the established criterion--240 minutes for the V2 system and 120 minutes for the V3.

Note 2. Numbers in parentheses after proportions are the number of times the emplacement criterion was met out of the total number of emplacement activities.

## Discussion

The purpose of the MANPRINT assessment was to identify human factors engineering, safety, health hazards, training, and manpower problems whose amelioration or correction could lead to satisfactory or enhanced operation and maintenance of the AN/TRC-170 system. Crew task performance times were compared to system performance criteria. Twenty-four findings were obtained.

Notably, most MANPRINT findings involved materials handling problems related to the emplacement and displacement of the AN/TRC-170 microwave relay station. Crewmen only monitor the radio functions after the equipment is powered up. Thus, there are no complex operating tasks. The AN/TRC-170 radio performed beyond expectations as a radio relay during the test. However, many of the problems found with the design of the equipment adversely affected the ease of assembly and disassembly. Time-consuming tasks were identified; hence both task organization and associated equipment characteristics may need reorganization, manpower changes, or equipment modification if emplacement time criteria are to be met.

The attendees of the MANPRINT scoring conference gave high priorities to nine of the 24 findings. The program manager's participation in the scoring conference should assure that the nine high priority problems are solved. They include the following:

1. The lack of high frequency radios;
2. Low mobilizer ground clearance;
3. Moving the mobilizer in reverse;
4. Discontinuous generator operation;
5. Noise levels in the shelters;
6. Steps and handrails on trucks;
7. Loading and unloading of the low-profile pallet;
8. Hearing protection for Pionjar operators; and
9. Training for Pionjar operations.

The manpower issue of crew size may not be resolved. However, much evidence supports the inclusion of a fourth man in the crew. Not only would emplacement tasks be performed more rapidly, but vehicle operation, perimeter security, and 24-hour operations would be facilitated. The manpower requirement for maintainers may have to be increased. The total number of maintainers allocated to the units was three. However, many delays resulted when maintainers had to travel great distances between field sites. During tactical operations, maintainers may be unable to travel such distances on a timely basis. Crewmen might be authorized to perform additional minor maintenance tasks, especially if the Army decides to authorize only one mechanic for every two AN/TRC units.

The MANPRINT findings for the AN/TRC-170 all involved areas that can be improved. Crewmen and maintainers are likely to perform tasks more rapidly once certain equipment design features are improved.

## REFERENCES

- Bowser, S. (1986, April). MANPRINT assessment annex: AN/TRC-170 digital troposcatter radio system, MANPRINT data collection forms and raw data. San Diego, CA: Bowser and Associates.
- Heuckeroth, O. H. (1988). Training assessment: The AN/TRC-170 digital troposcatter radio system. Alexandria, VA: U.S. Army Research Institute for the Behavioral and Social Sciences.
- U.S. Army Test and Evaluation Command (1983, November). Test operations procedures, human factors engineering, Part I--Test procedures, Part II--HEDGE (TOP 1-2-610, Parts I and II). Aberdeen Proving Ground, MD.